

THE  
CITY OF RIDGELAND  
MADISON COUNTY, MISSISSIPPI

CONSTRUCTION PLANS FOR THE  
GATEWAY SUBDIVISION SEWER IMPROVEMENTS PROJECT

MAYOR  
GENE F. McGEE  
MAYOR PRO TEM  
CHUCK KOBERT  
BOARD OF ALDERMEN  
HARVEY CARR, JR.  
DARYL SMITH  
BRIAN BARCELLONA  
AL BIBLE  
JOE BARLOW  
LINDA DAVIS

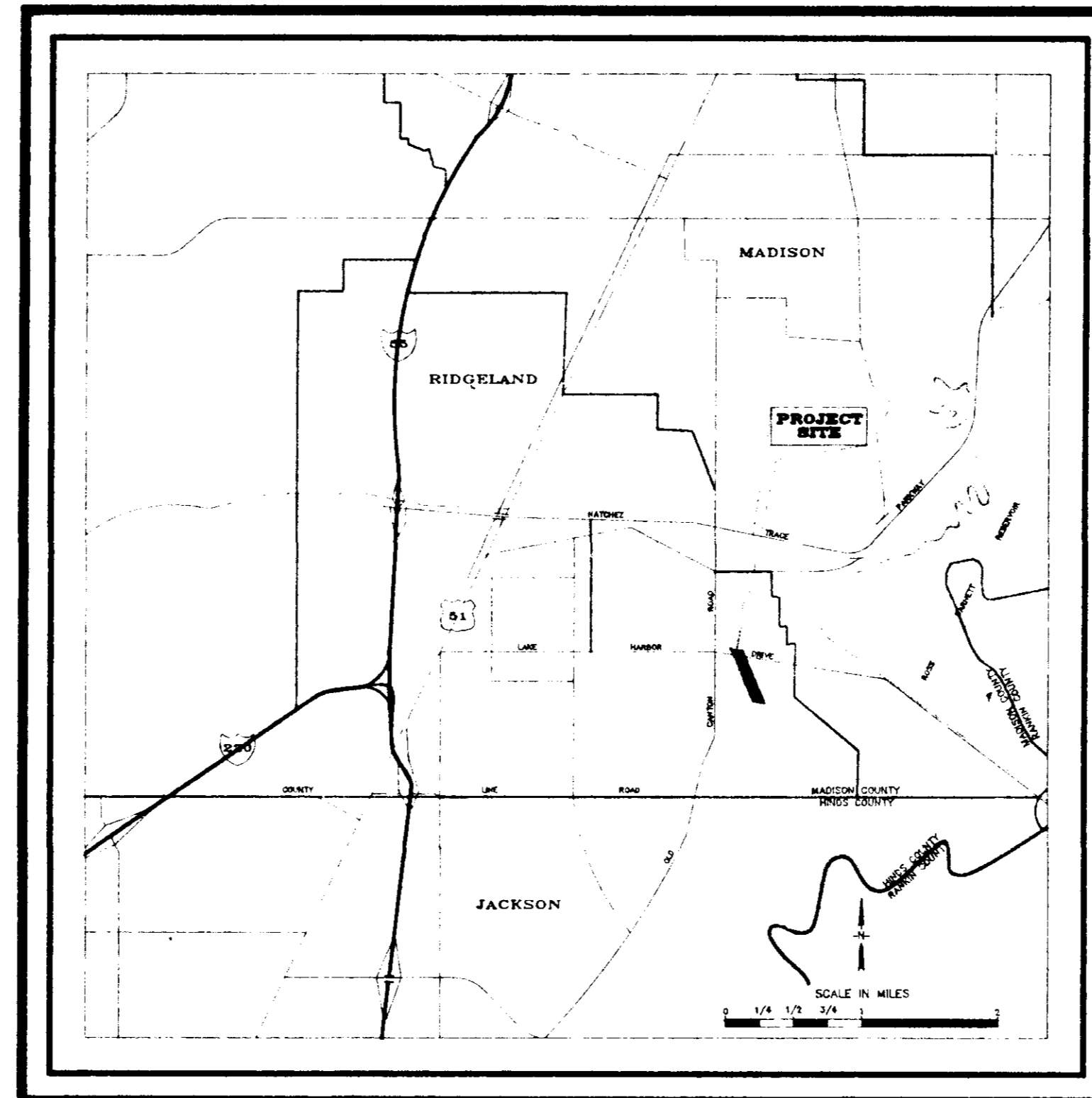

VICINITY MAP

PUBLIC WORKS DIRECTOR  
SAM C. VINSON, P.E.  
ASSISTANT PUBLIC WORKS DIRECTOR  
SID HAWTHORNE  
CITY ATTORNEY  
JERRY MILLS  
CITY CLERK  
MIKE McPHEARSON

BONNER ENGINEERING  
JACKSON, MISSISSIPPI

MARCH 1995

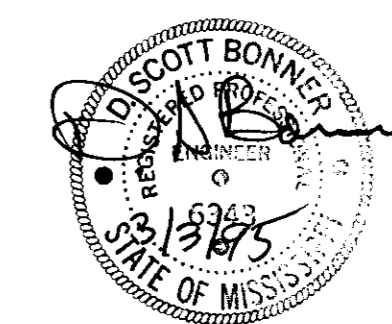

PWP-00702



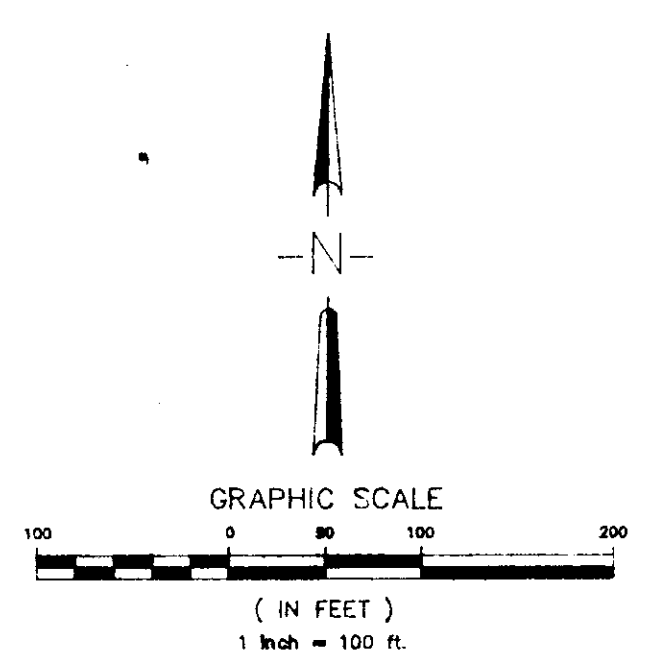
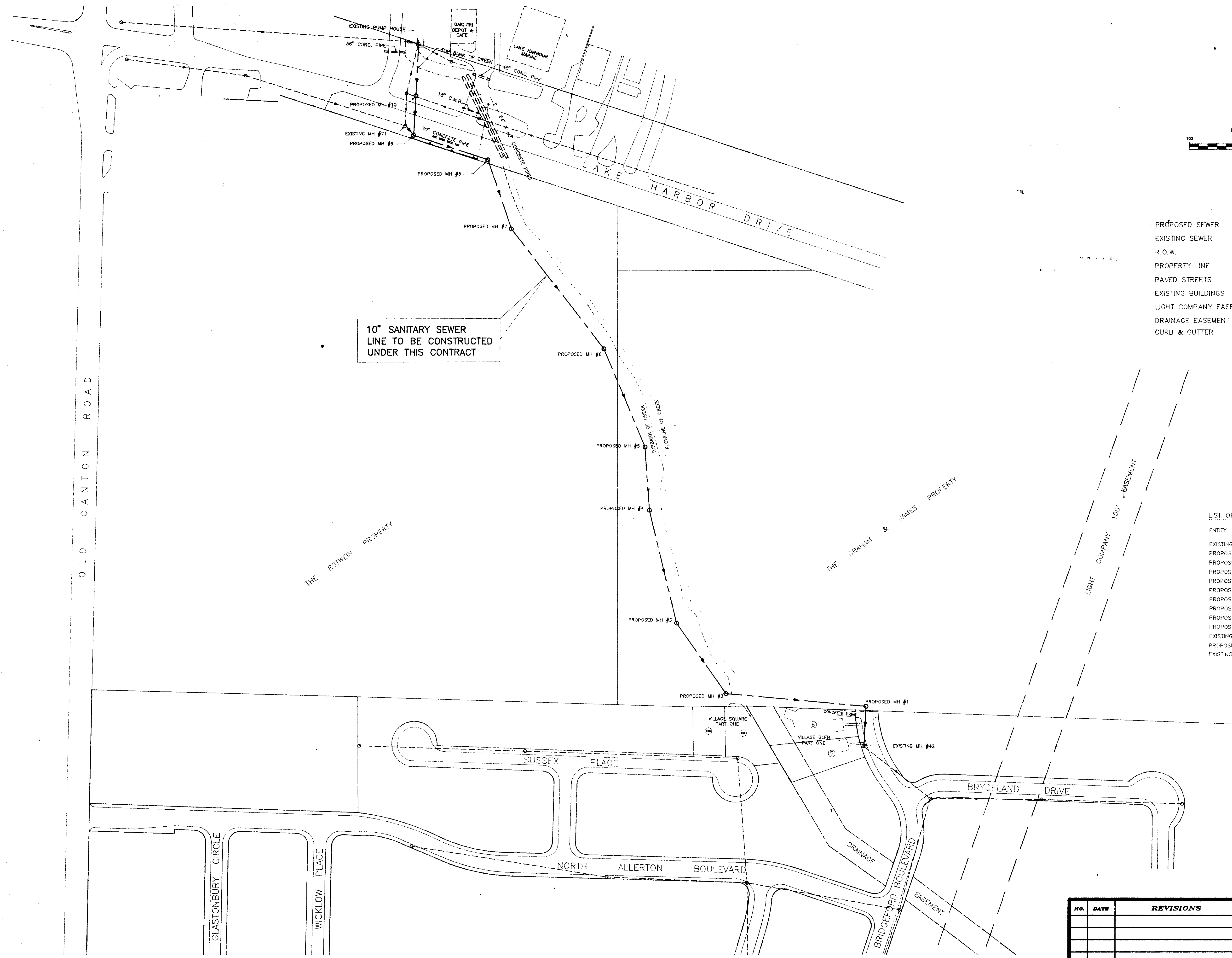

**LEGEND**

- PROPOSED SEWER
- EXISTING SEWER
- R.O.W.
- PROPERTY LINE
- PAVED STREETS
- EXISTING BUILDINGS
- LIGHT COMPANY EASEMENT
- DRAINAGE EASEMENT
- CURB & GUTTER

**LIST OF COORDINATES (ASSUMED)**

ENTITY	NORTH	EAST
EXISTING MH #42	9912.58	10017.41
PROPOSED MH #1	9998.02	10021.99
PROPOSED MH #2	10026.75	9717.61
PROPOSED MH #3	10181.00	9609.70
PROPOSED MH #4	10426.51	9550.50
PROPOSED MH #5	10564.60	9541.07
PROPOSED MH #6	10778.64	9451.27
PROPOSED MH #7	11040.56	9249.79
PROPOSED MH #8	11191.77	9198.29
PROPOSED MH #9	11245.54	9036.10
EXISTING MH #71	11266.82	9019.26
PROPOSED MH #10	11370.80	9040.83
EXISTING PUMP HOUSE	11444.62	9047.57

NO.	DATE	REVISIONS	BY

<b>CITY OF RIDGELAND</b>		
<b>RIDGELAND, MISSISSIPPI</b>		
<b>GATEWAY SUBDIVISION SEWER IMPROVEMENTS</b>		
<b>PROJECT LOCATION &amp; LAYOUT</b>		
<b>BONNER ENGINEERING</b>		
<b>JACKSON, MISSISSIPPI</b>		
DRAWN BY: AA	DATE: 03/08/05	SHEET NUMBER
REVIEWED BY: DSB	SCALE: 1" = 100'	3 OF 7

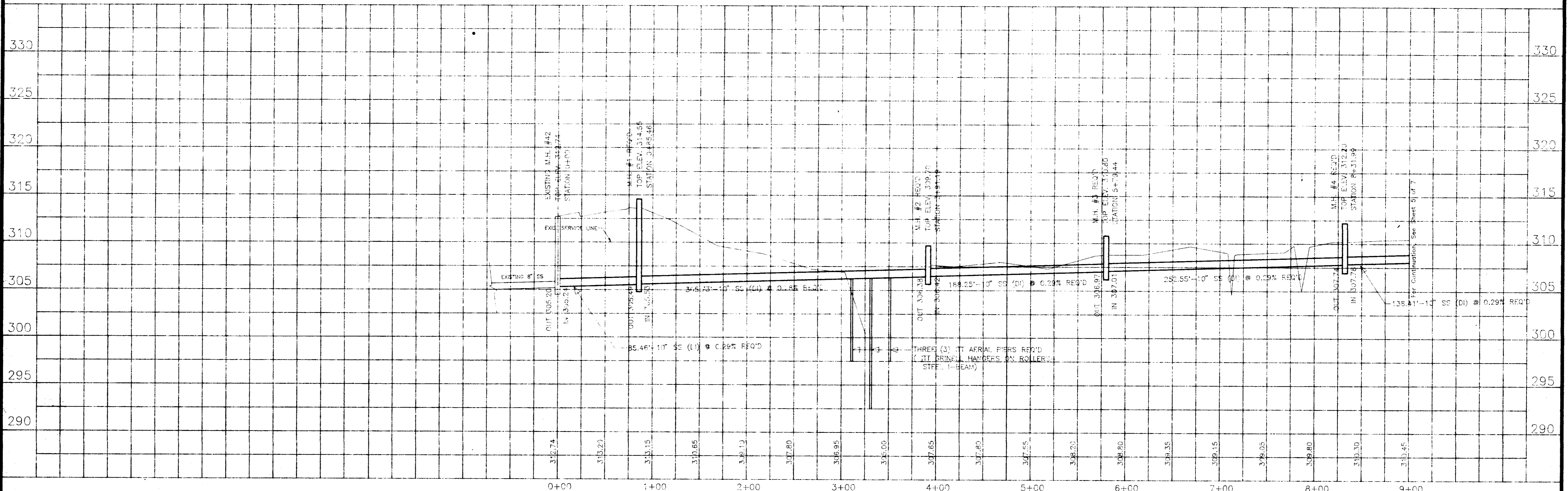
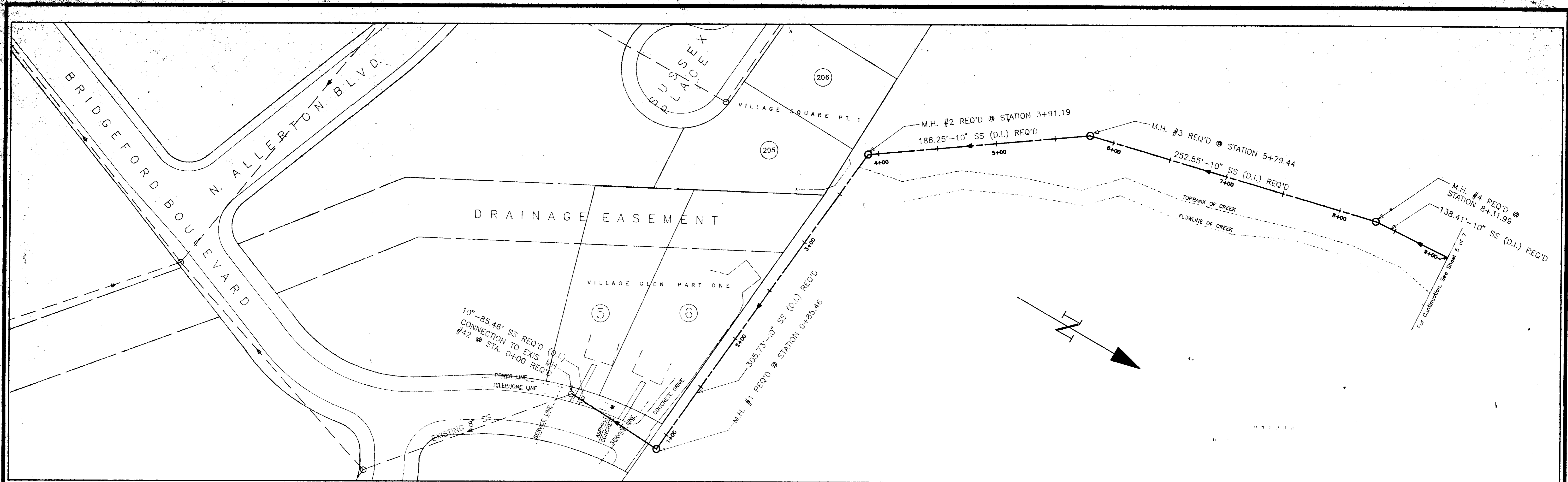

DESIGNED BY AA		PROFILE SCALE 1" = 8' HORIZ. 1" = 40' VERT.		BONNER ENGINEERING JACKSON, MISSISSIPPI		GATEWAY SUBDIVISION SEWER IMPROVEMENTS 10" SANITARY SEWER LINE FROM STATION 0+00 TO STATION 9+00		CITY OF RIDGELAND RIDGELAND, MISSISSIPPI		DATE 03-02-95	
CHECKED BY DSB		PLAN SCALE 1" = 40'								SHEET NO. 4 OF 7	
REVISIONS											
NO.	DATE	BY									

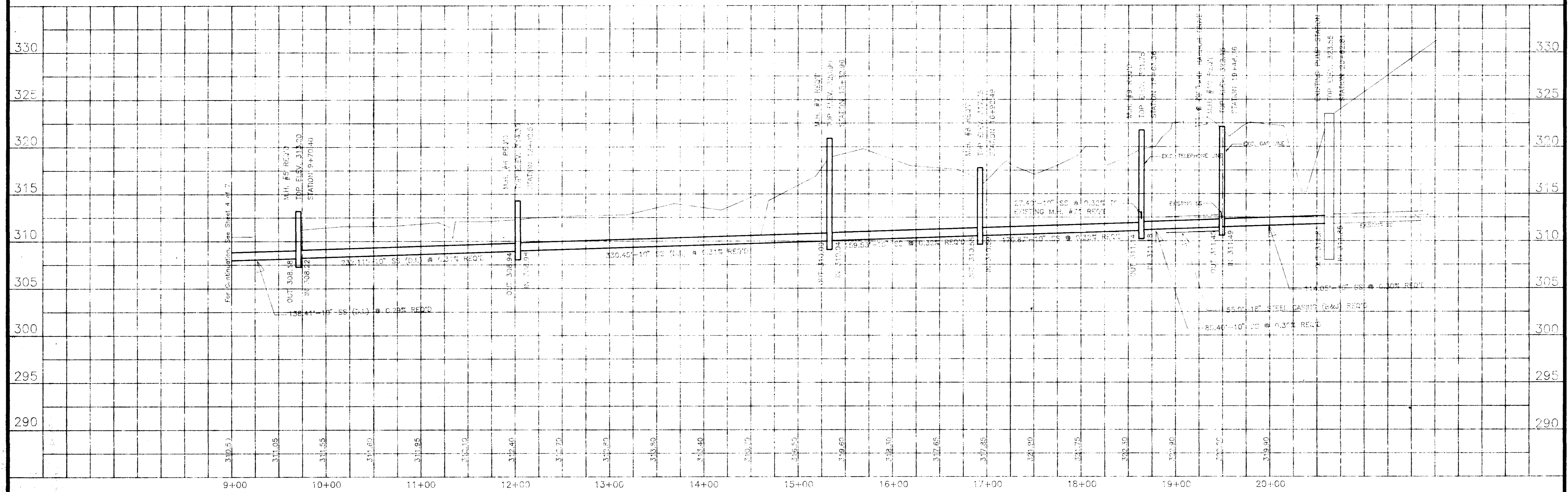
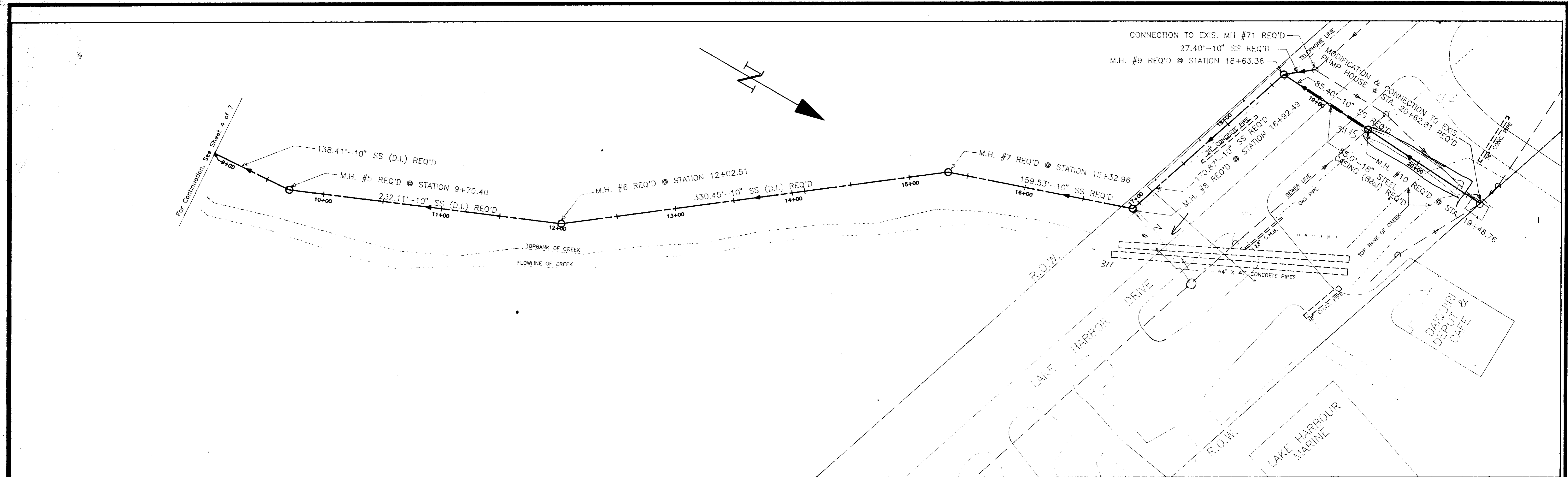

DESIGNED BY AA		PROFILE SCALE 1" = 20' HORT 1" = 5' VERT	BONNER ENGINEERING JACKSON, MISSISSIPPI	GATEWAY SUBDIVISION SEWER IMPROVEMENTS 10" SANITARY SEWER LINE FROM STATION 9+00 TO STATION 20+62.81 AND FROM STATION 18+63.36 TO EXIS. M.H. #71	CITY OF RIDGELAND RIDGELAND, MISSISSIPPI	DATE 03-02-95
CHECKED BY DSB		PLAN SCALE 1" = 40'				SHEET No. 5 OF 7
NO.	DATE	REVISIONS				

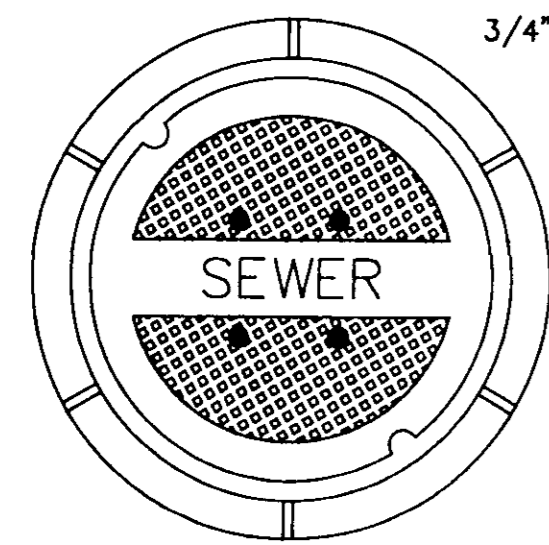

TOP PLAN OF COVER

FRAME & COVER WEIGHT 420 LBS.

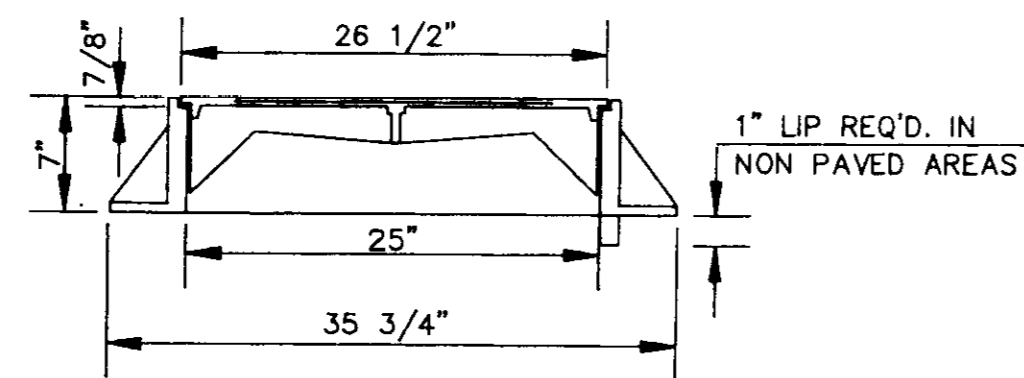

SECTION

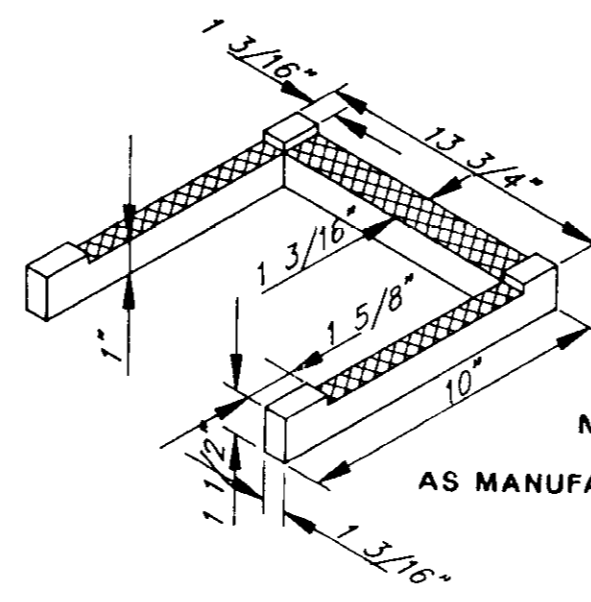

DETAIL 'B'

MODEL NO. PS2 - PF  
AS MANUFACTURED BY M.A. INDUSTRIES INC.

**STANDARD MANHOLE FRAME AND COVER**

N.T.S.

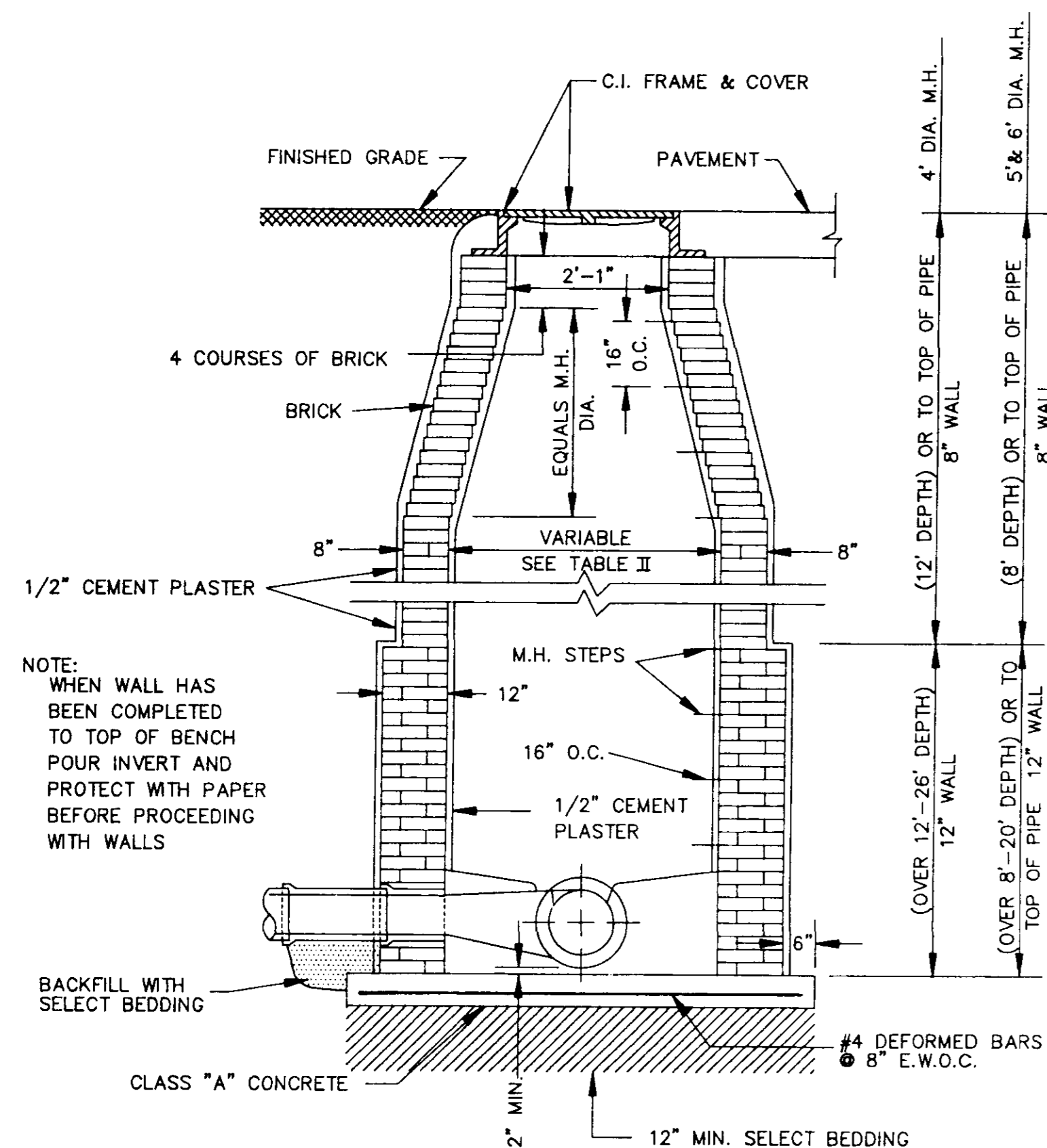

**STANDARD BRICK MANHOLE**

N.T.S.

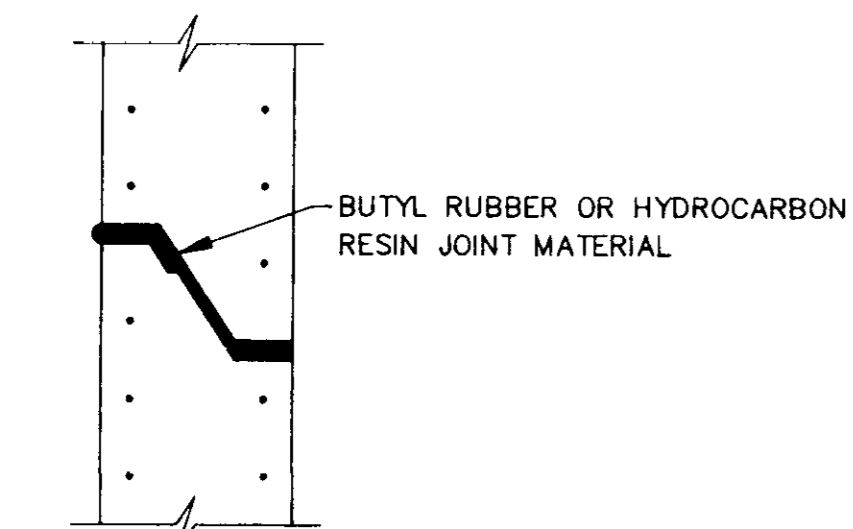

**TYPICAL PRECAST CONCRETE MANHOLE JOINT DETAIL**

N.T.S.

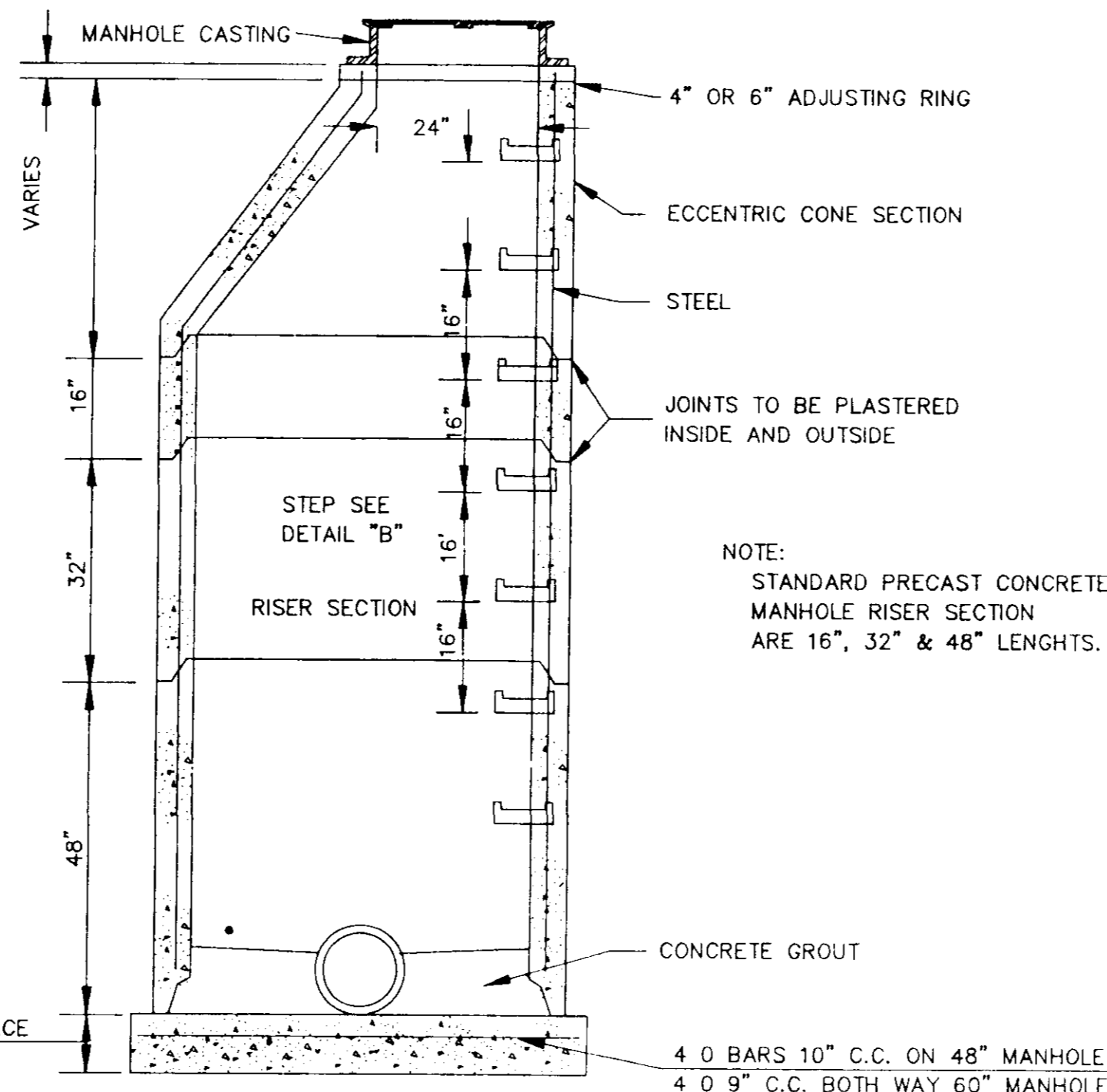

**SECTION OF PRECAST CONCRETE MANHOLE**

N.T.S.

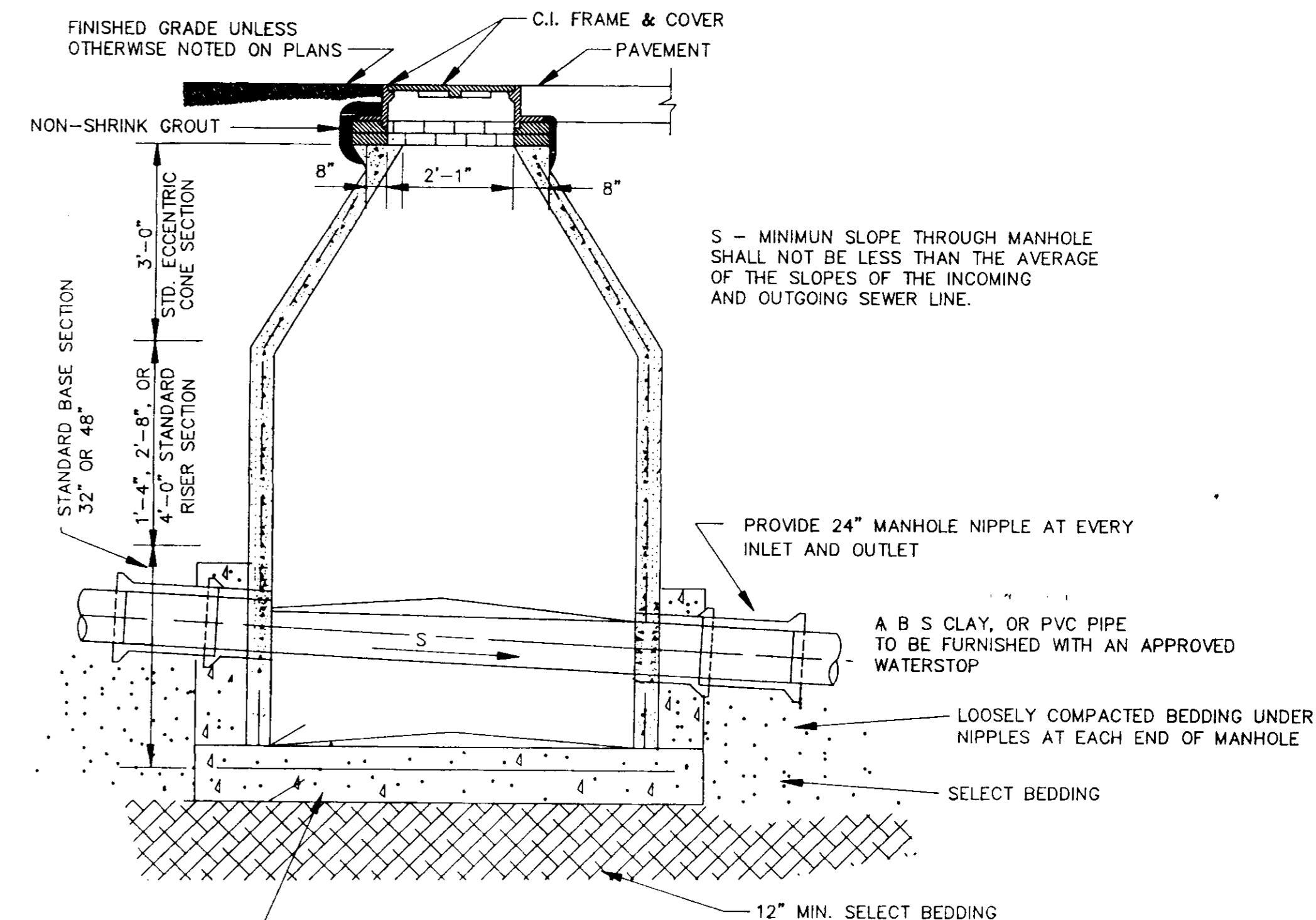

**SECTION B-B**

N.T.S.

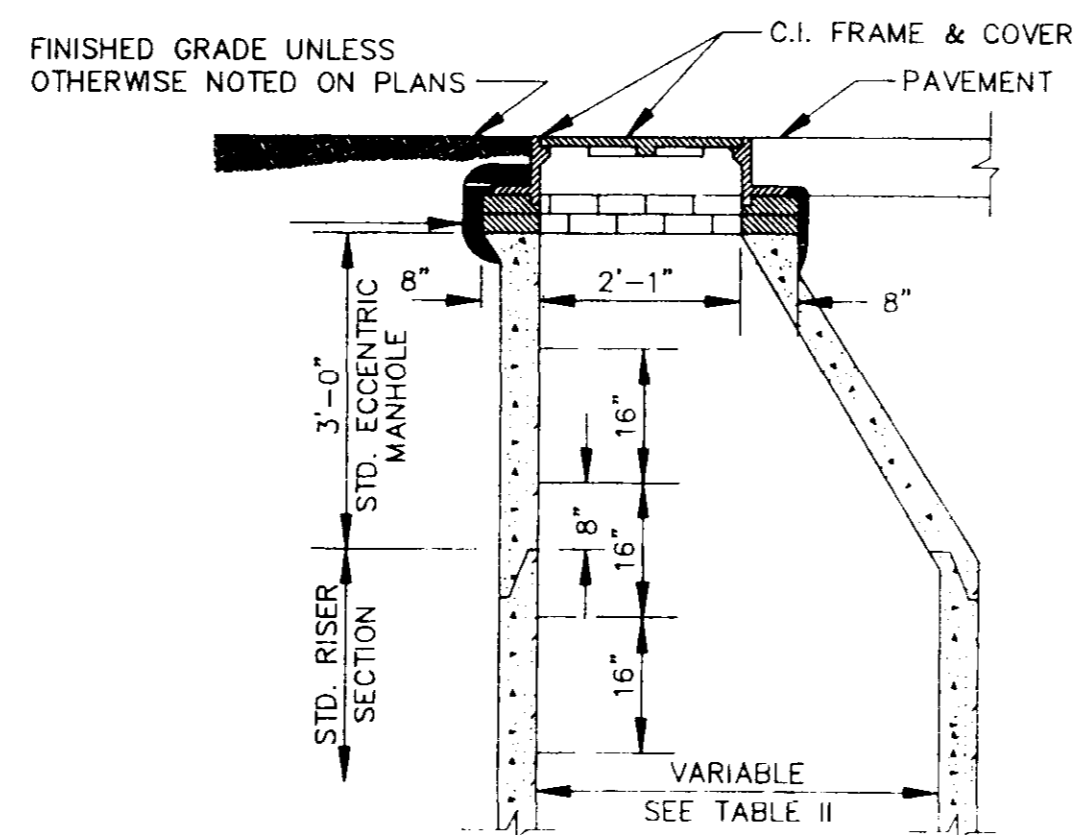

**STANDARD ECCENTRIC CONE FOR ALL DIAMETER MANHOLES**

N.T.S.

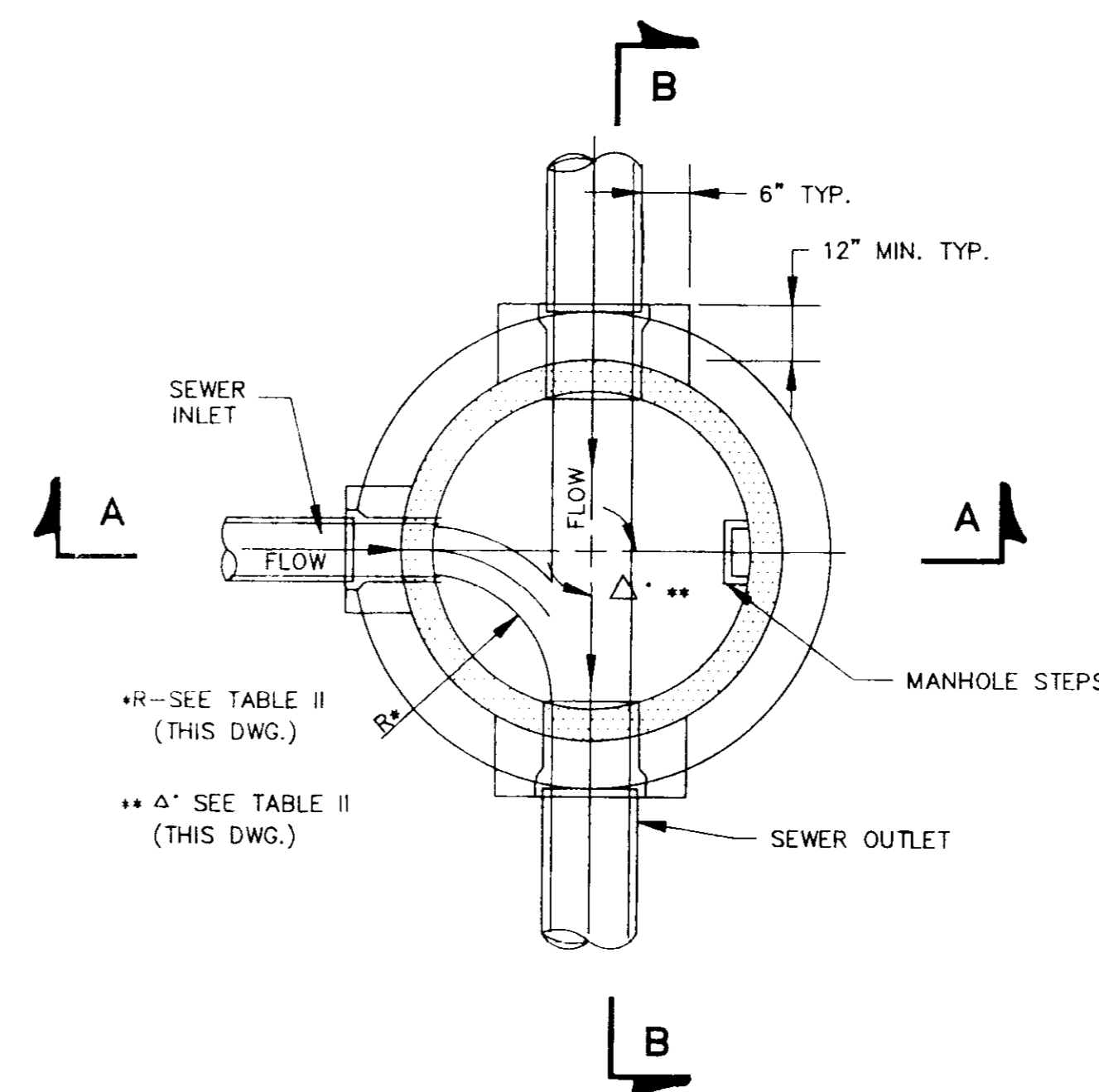

**SECTIONAL PLAN STANDARD MANHOLE**

N.T.S.

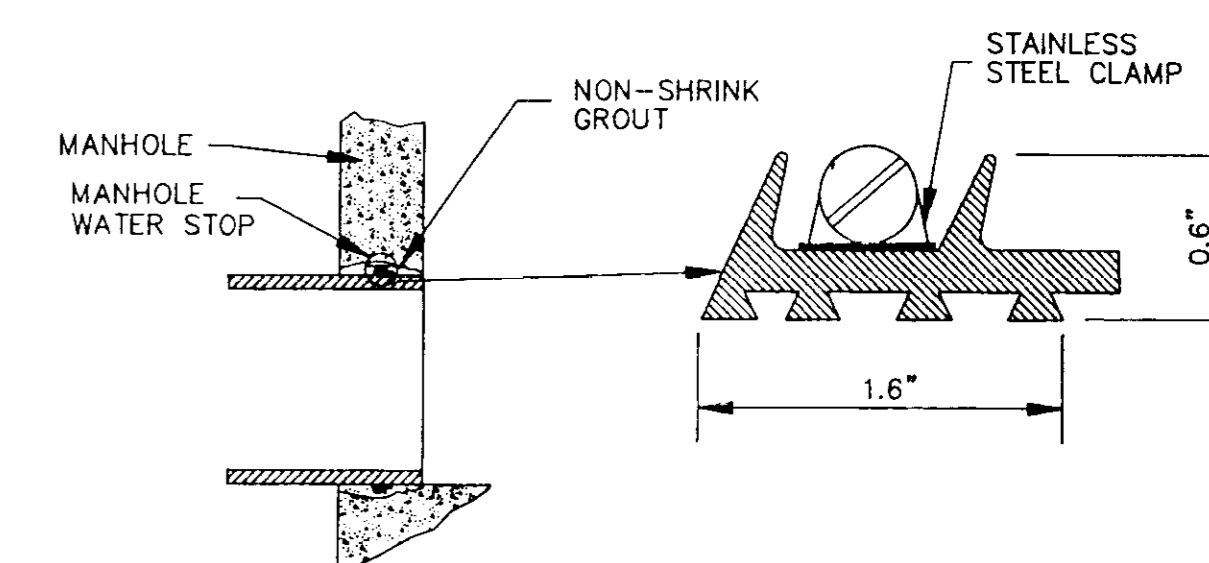

**TYPICAL MANHOLE WATER STOP FOR ABS, CLAY OR PVC PIPE**

EXISTING AND "STRADDLE" MANHOLES  
N.T.S.

CITY OF RIDGELAND, MS.

**STANDARD DETAILS**

DSGN:			DRAWING NO.
DRWN:			OF
CHKD:			
SCALE:			

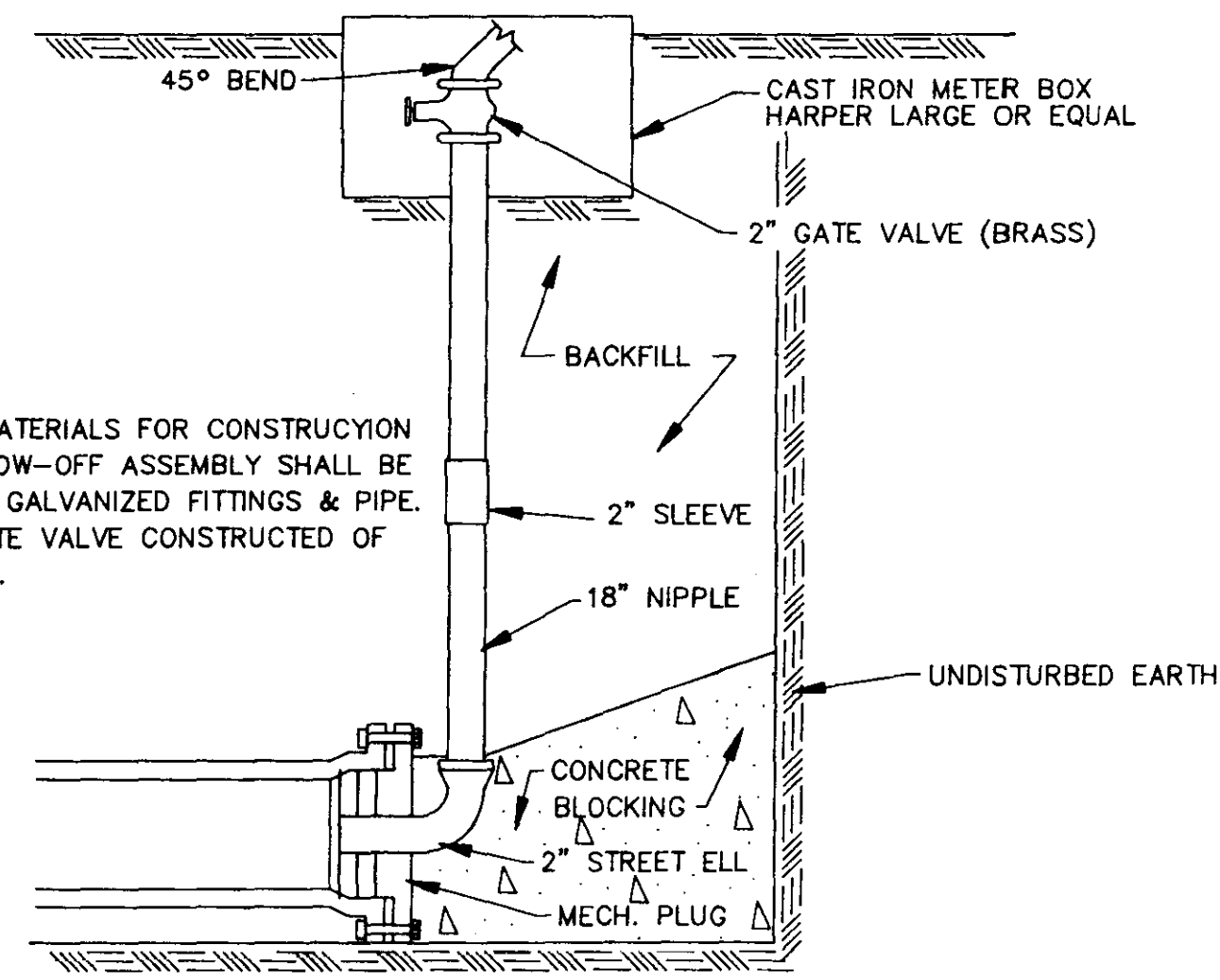

**NOTE:**  
ALL MATERIALS FOR CONSTRUCTION OF BLOW-OFF ASSEMBLY SHALL BE OF 2" GALVANIZED FITTINGS & PIPE. 2" GATE VALVE CONSTRUCTED OF BRASS.

**TYPICAL BLOW-OFF ASSEMBLY**  
N.T.S.

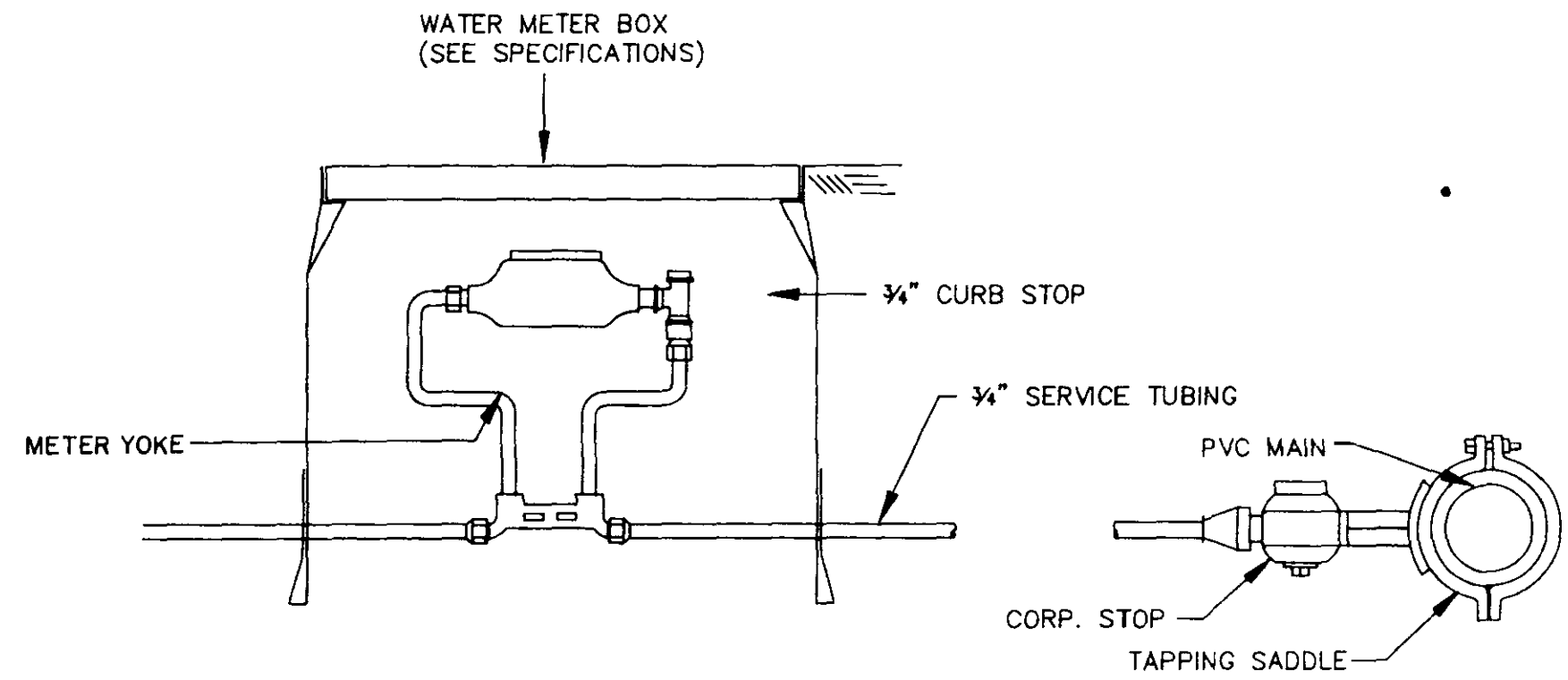

**TYPICAL 3/4" WATER SERVICE**  
N.T.S.

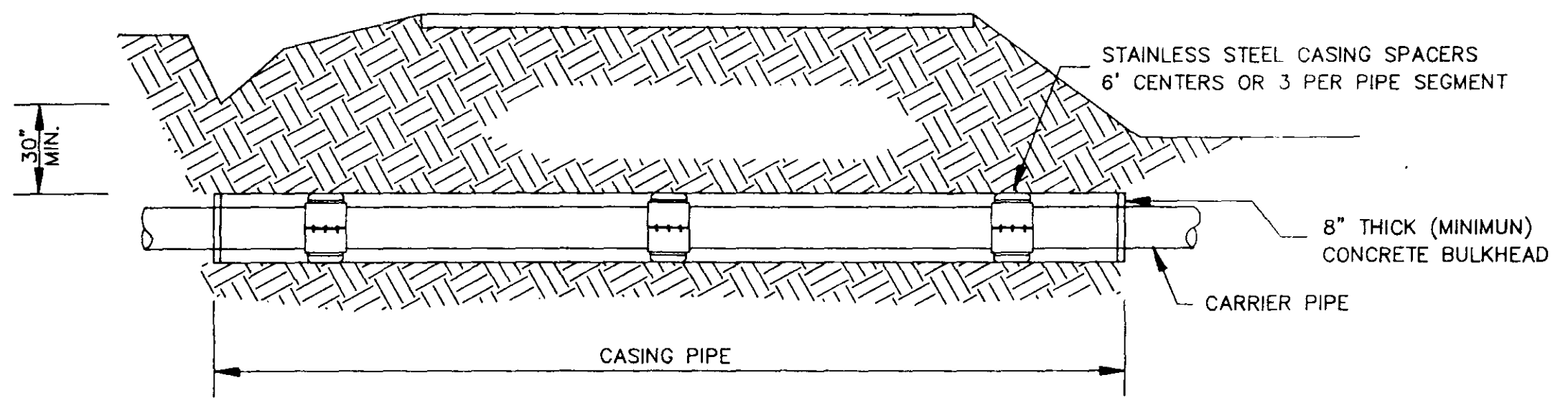

**TYPICAL BORE SECTION**  
N.T.S.

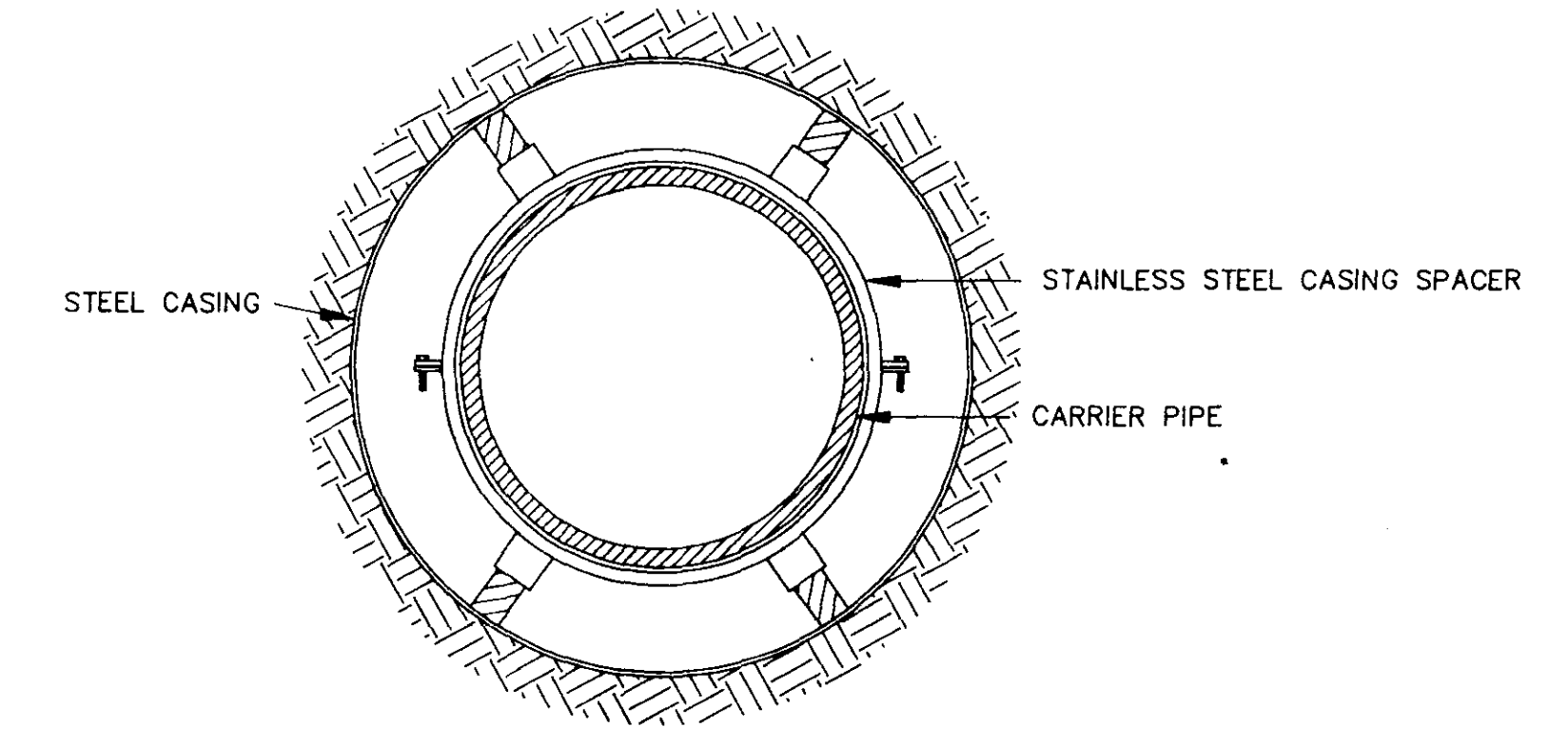

**BORE SECTION**  
N.T.S.

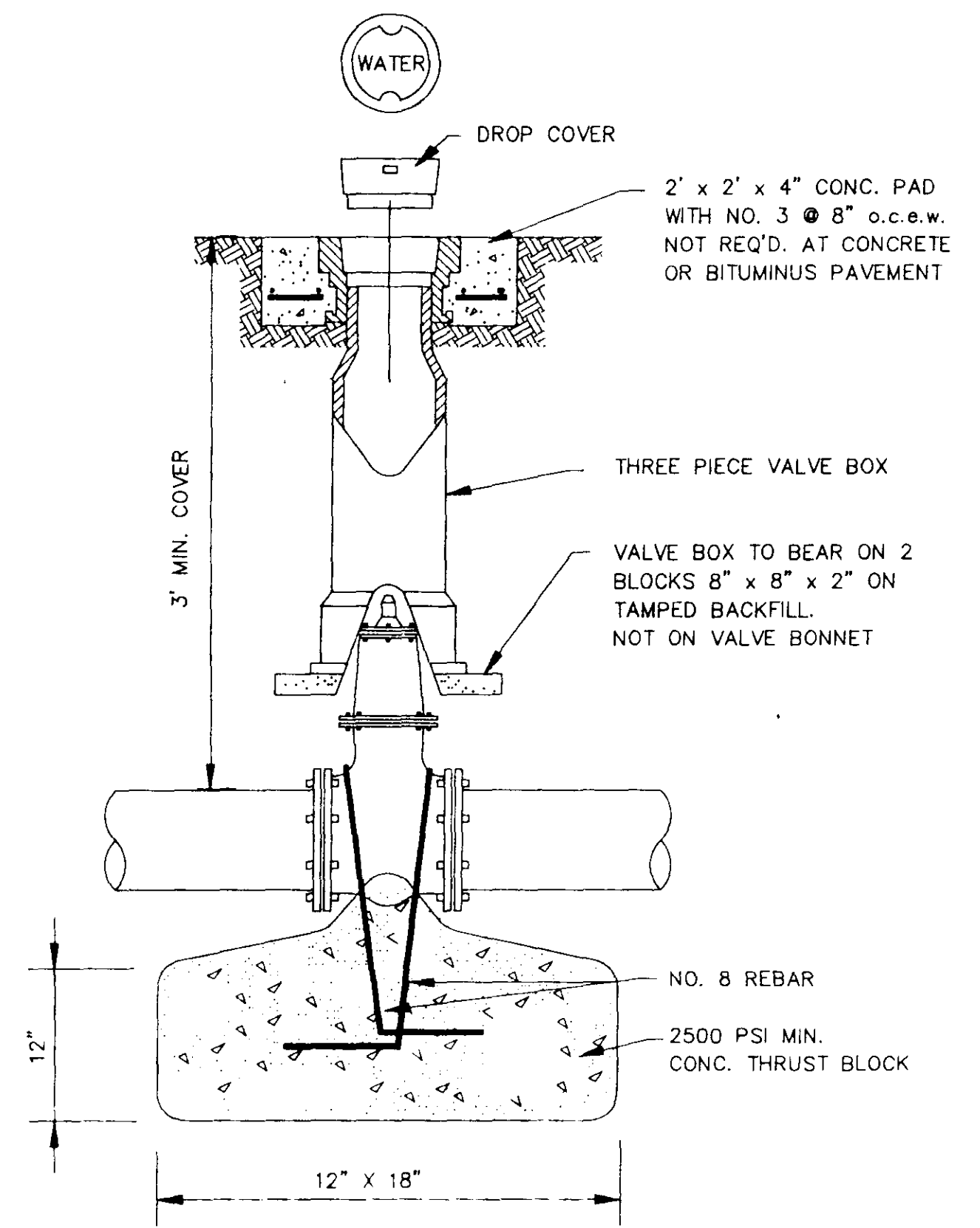

**GATE VALVE DETAIL**  
N.T.S.

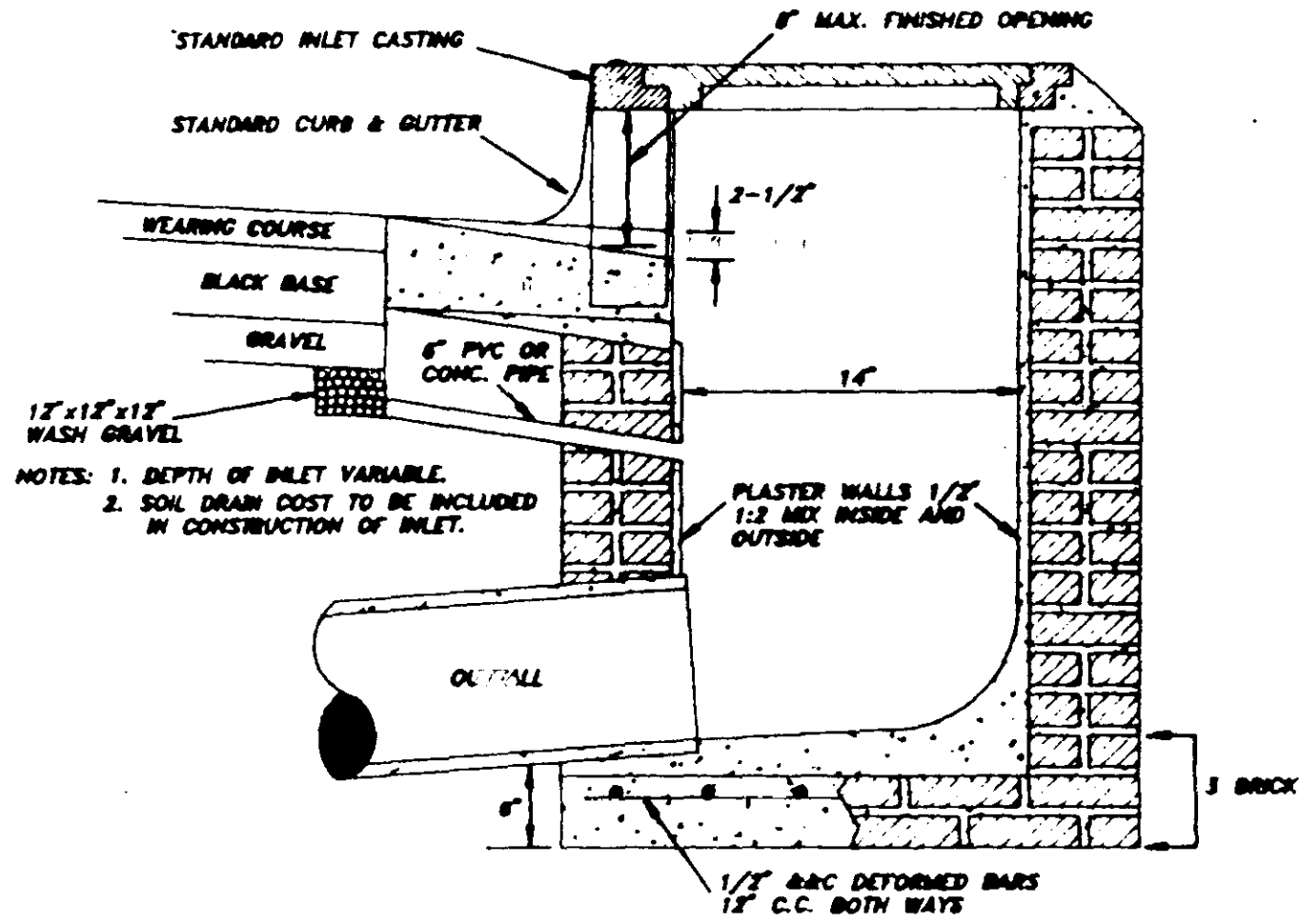

**SECTION OF STANDARD CURB INLET**

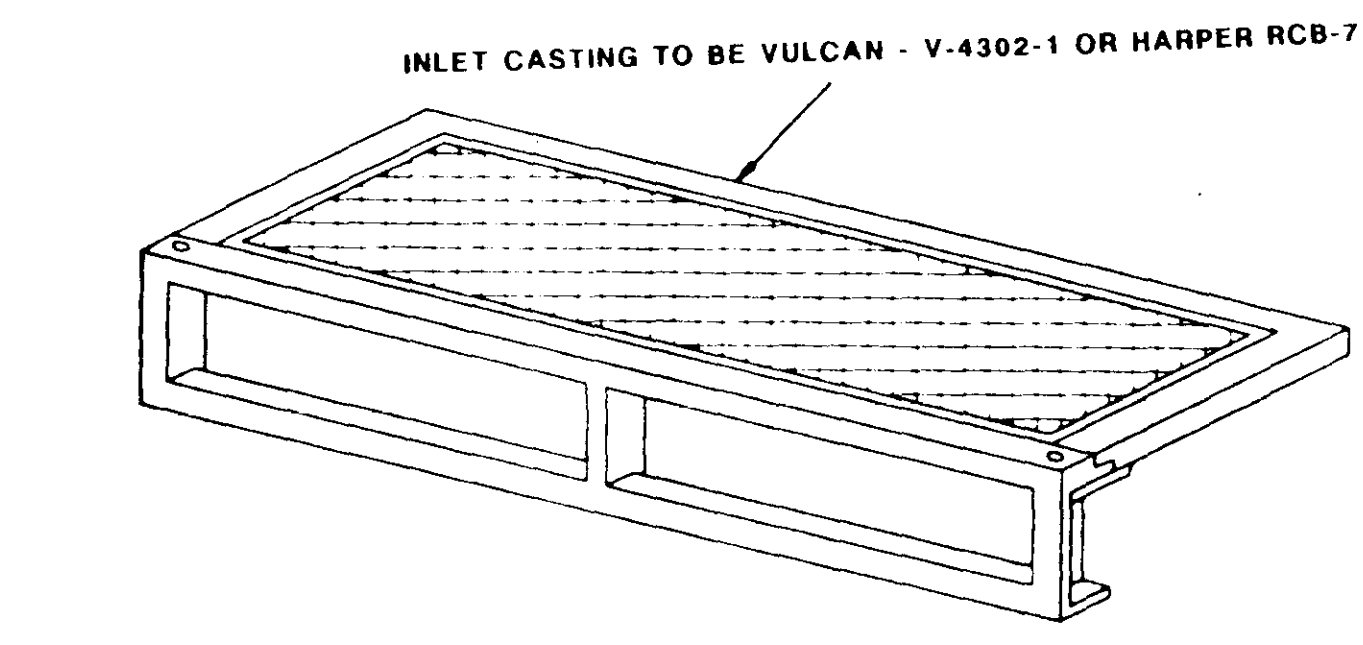

**STANDARD CURB INLET CASTING**

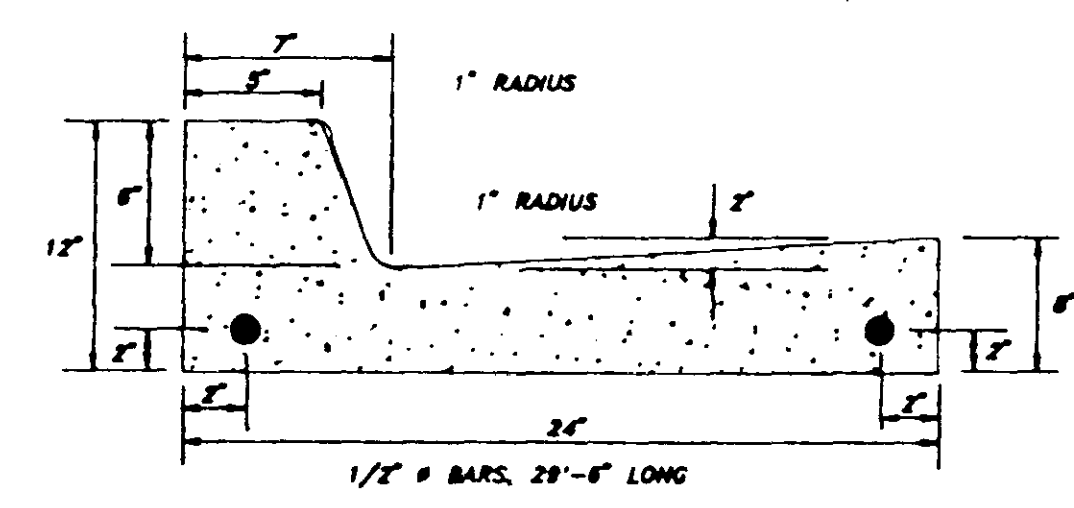

**NOTES:** 1. ALL CURBS, GUTTERS & DRIVEWAYS TO BE CONSTRUCTED OF 3000 LB. CONCRETE.  
2. 2 - 3/4" DOWEL BARS, 15" LONG REQ'D. AT EXPANSION JOINTS. THEY SHALL BE HELD IN PLACE BY APPROVED CHAIRS OR SUPPORTS AND 1/2" EXPANSION MATERIALS.

**STANDARD CURB & GUTTER**

**CITY OF RIDGELAND, MS.**

**STANDARD DETAILS**

DSGN:			DRAWING NO.
DRWN:			OF
CHKD:			
SCALE:			

REVISION 7/7/76 FROM 4/7/65