

CURVE DATA

D	T	R	L	D
29°30'00"	70.00'	265.88'	136.89'	21°32'58"

PLAN & PROFILE - GOODRIDGE DRIVE
 SCALE: PLAN: 1" = 50'
 PROFILE: 1" = 50' HORIZONTAL
 1" = 5' VERTICAL

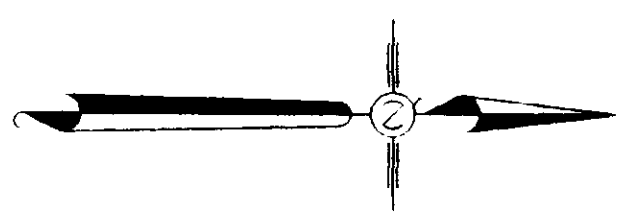
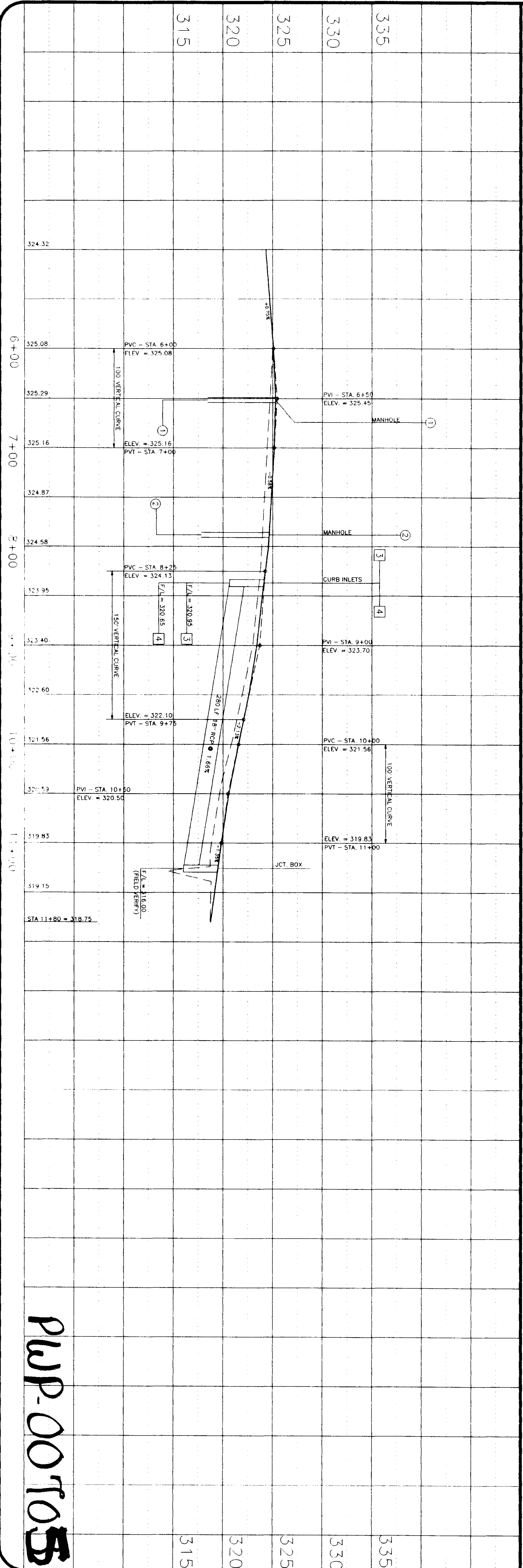

RECEIVED
 OCT 09 1997
 PUBLIC WORKS DEPT.

PWP-00705

Designed: KARL P. LONG
 Drawn: BTG
 Approved: KARL P. LONG
 Date: SEPT. 8, 1997

GOODRIDGE CENTER
 RIDGELAND, MISSISSIPPI

Central Mississippi Engineering
 115 E. MAIN ST. FLORENCE, MS 39073

Revision

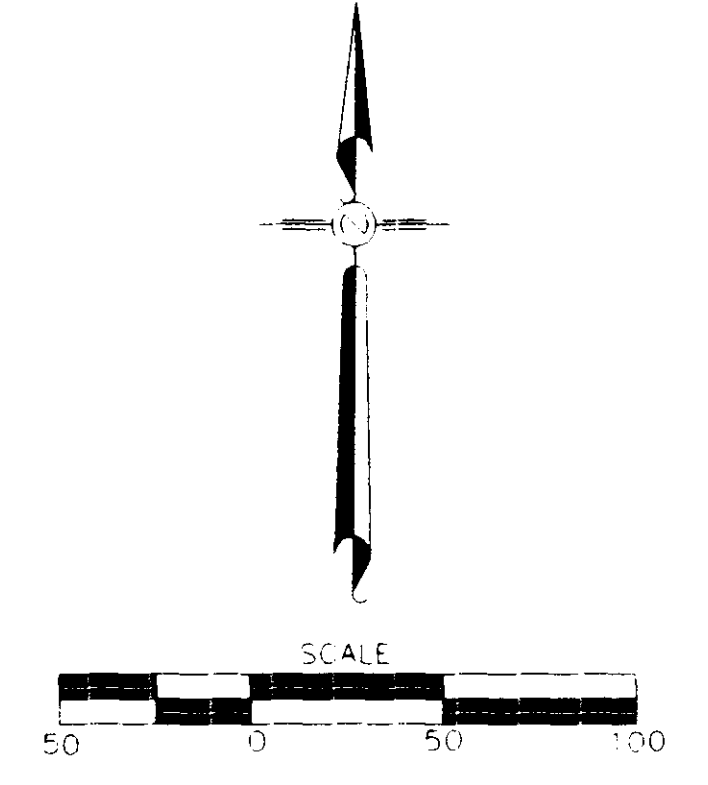
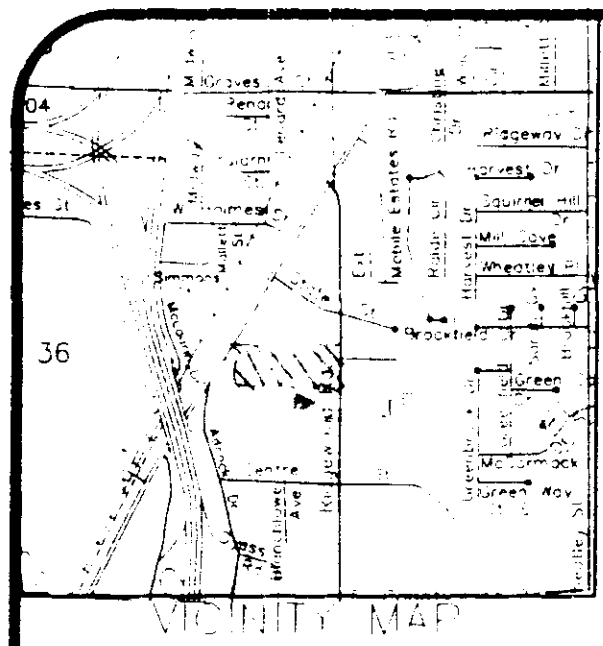

NOTES:
 CONTOURS ARE TAKEN FROM FIELD SURVEY
 AND ARE BASED ON NGVD.
 SITE IS 11.2 ACRES.
 THIS PLAT IS BASED ON CLASS "B" SURVEY
 DATED: AUGUST 9, 1996.

DEVELOPER:
 EDDIE GOODE
 435 NORTH HIGHLAND
 SUITE 1
 MEMPHIS, TN 38122

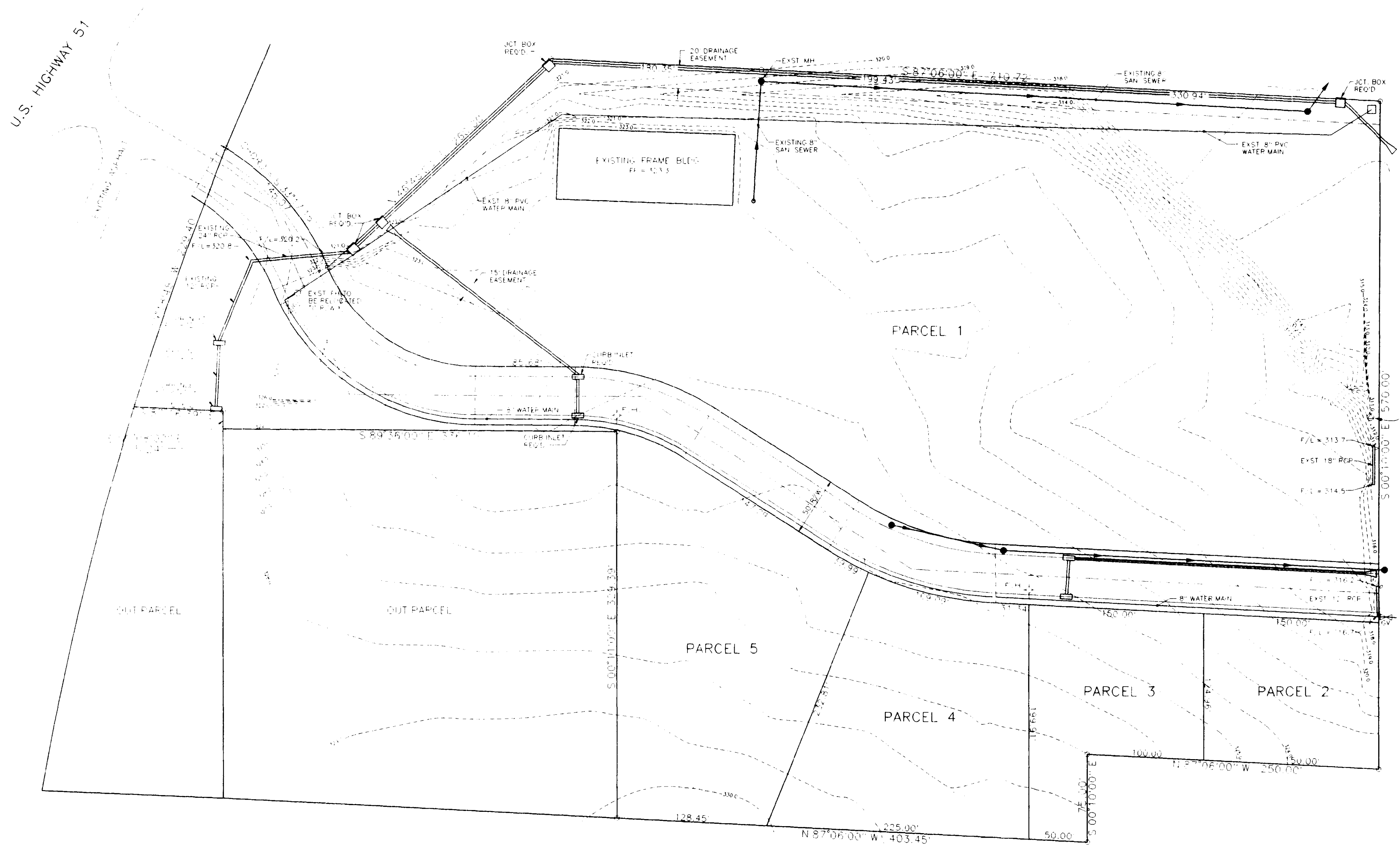

TBM - BM 172
 LAY OUT TAND WASHER
 IN P.P.
 ELEV = 316.21 NGVD

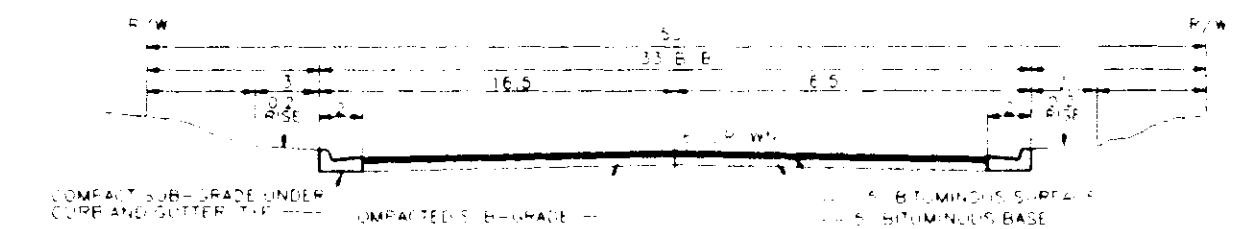

TYPICAL STREET SECTION
 NOT TO SCALE



PRELIMINARY PLAT

Project No. _____

CENTRAL MISSISSIPPI ENGINEERING, INC.
 115 EAST MAIN STREET FLORENCE, MISSISSIPPI

GOODRIDGE CENTER
 RIDGELAND, MISSISSIPPI

Checked: MARK P. LONG
 Drawn: _____
 Approved: _____
 Date: _____

Sheet No. _____

GOODRIDGE CENTER
 STORM DRAINAGE COMPUTATIONS - 25 YR. STORM

RUNOFF: $Q = CIA$ CAPACITY: $Q = C \times S^2$
 $C = 0.75$ $C = (1.46/n) \times A \times R^2$
 $I = 9.0 \text{ IN./HR}$ $S = \text{SLOPE}$
 $A = \text{DRAINAGE AREA}$ $N = 0.013$

NOTE: C is taken from Table 3 in the "Concrete Pipe Design Manual" published by the American Concrete Pipe Association.

Inlet #1 DA = 3.5 AC 28" x 18" @ 1.60%
 $Q = (0.75)(9.0)(3.5)$ $(187)(0.1265)$
 $Q = 23.6 \text{ cfs}$ $Q = 23.6 \text{ cfs}$

Inlet #2 DA = 0.7 AC 27" @ 0.96%
 $Q = (1.00)(9.0)(0.7) + Q1$ $(310)(0.0980)$
 $= 6.3 + 23.6$ $Q = 30.3 \text{ cfs}$
 $Q = 29.9 \text{ cfs}$

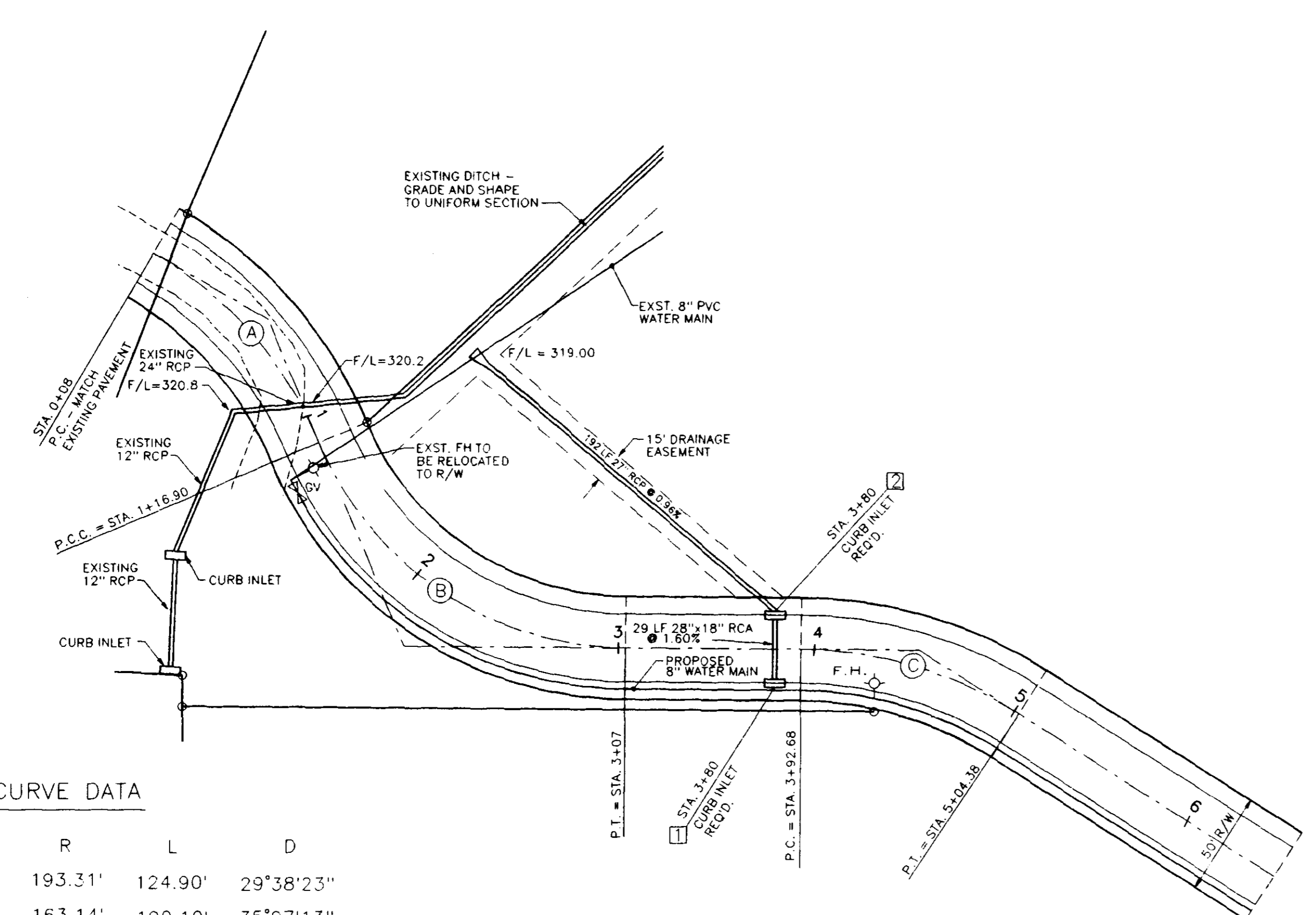
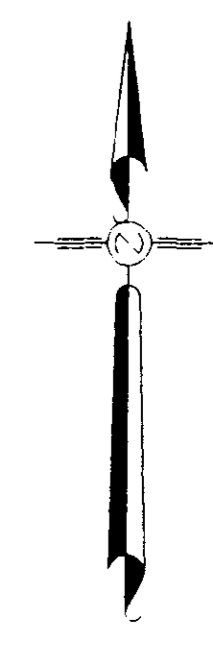

CURVE DATA

	Δ	T	R	L	D
A	37°01'17"	64.72'	193.31'	124.90'	29°38'23"
B	66°45'36"	107.49'	163.14'	190.10'	35°07'13"
C	32°00'00"	57.35'	200.00'	111.70'	28°38'51"

PLAN & PROFILE - GOODRIDGE DRIVE
 SCALE:
 PLAN: 1" = 50'
 PROFILE: 1" = 50' HORIZONTAL
 1" = 5' VERTICAL

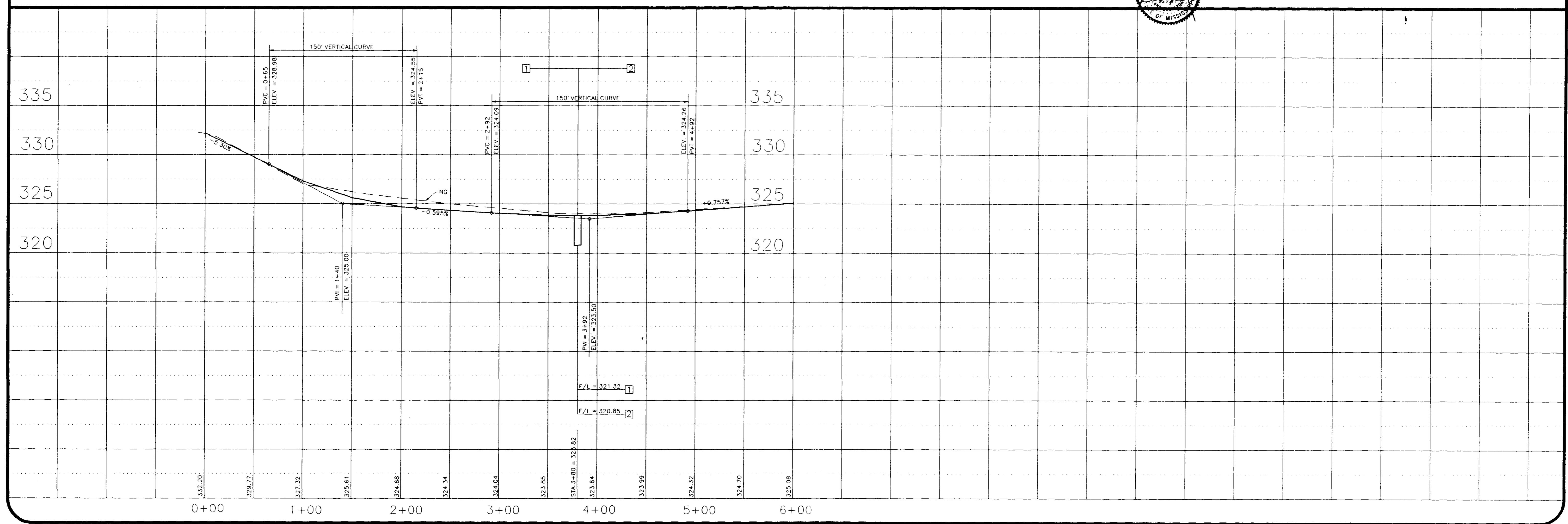
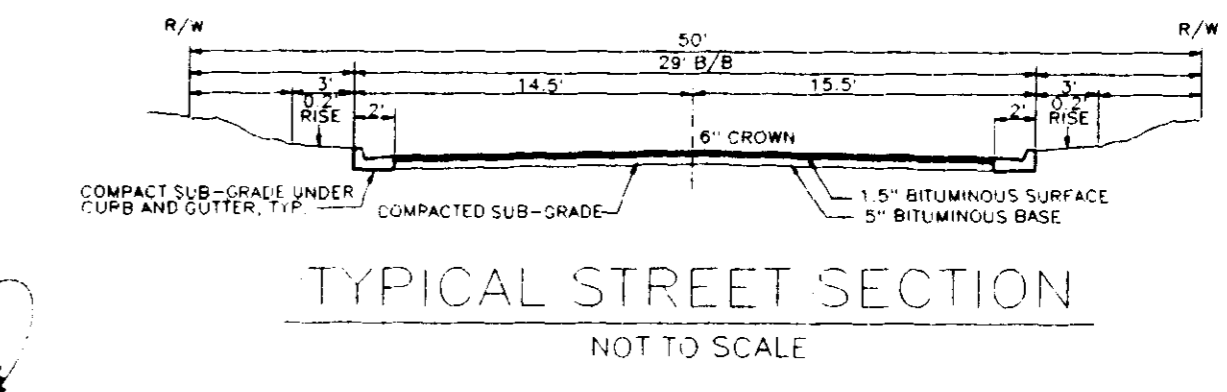
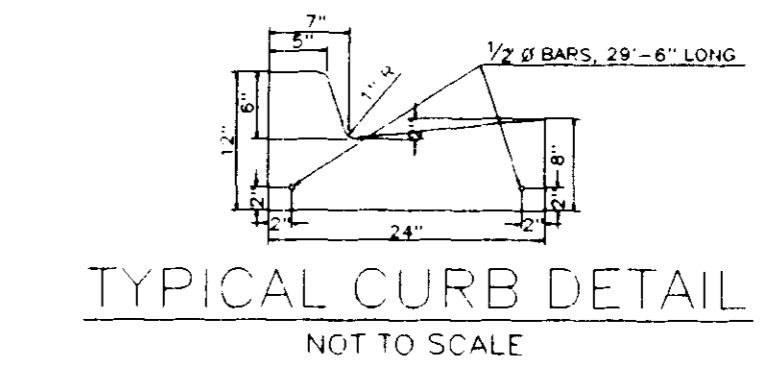

Revision

Central Mississippi Engineering
 115 E. MAIN ST. FLORENCE, MS 39073

GOODRIDGE CENTER
 RIDGELAND, MISSISSIPPI

Designed: KARL P. LONG
 Drawn: BIG
 Approved: KARL P. LONG
 Date: JULY 23, 1997

