

CONSTRUCTION PLANS  
FOR

# WENDOVER PART 2A

## CITY OF RIDGELAND MADISON COUNTY, MISSISSIPPI

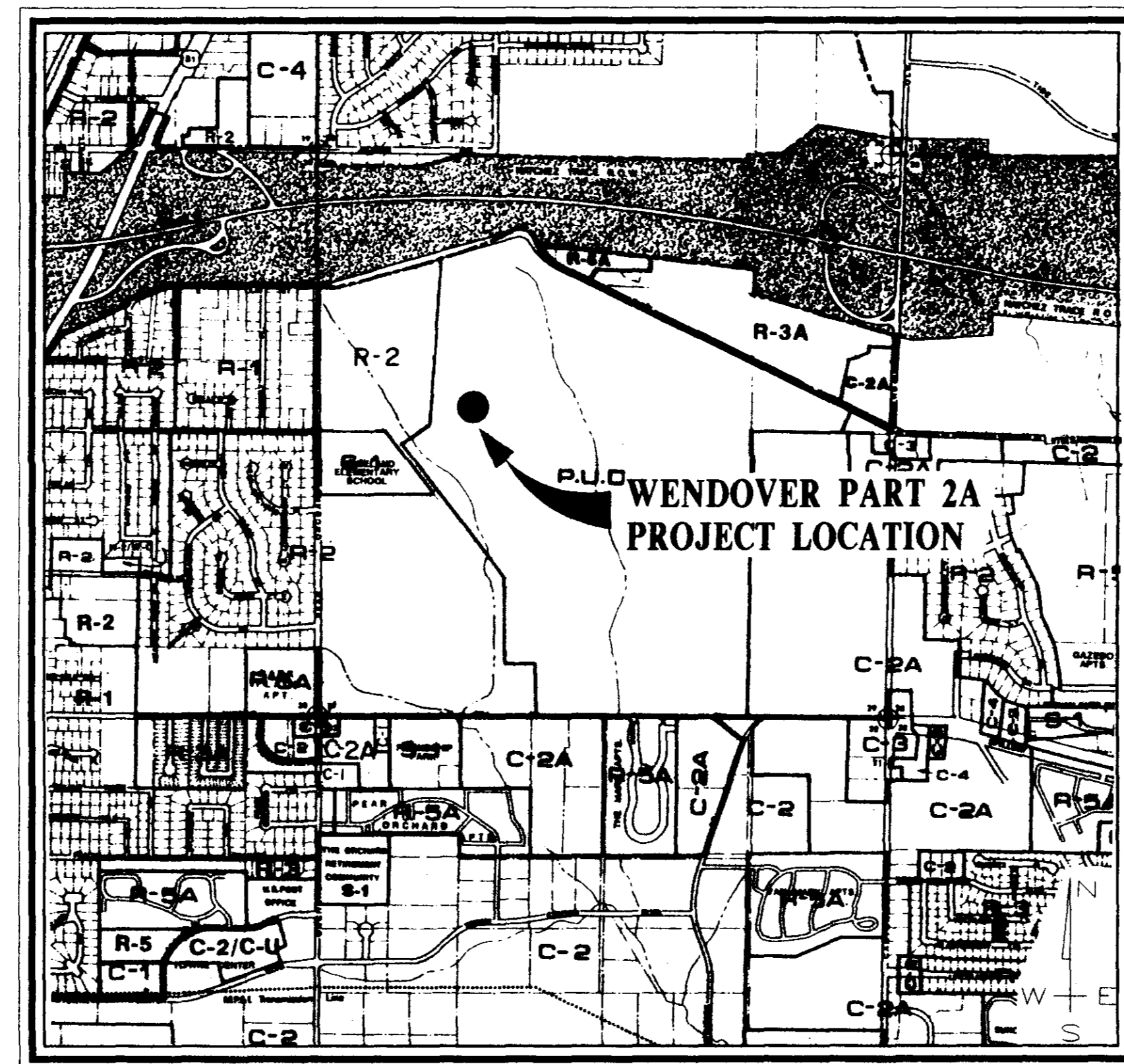

VICINITY MAP

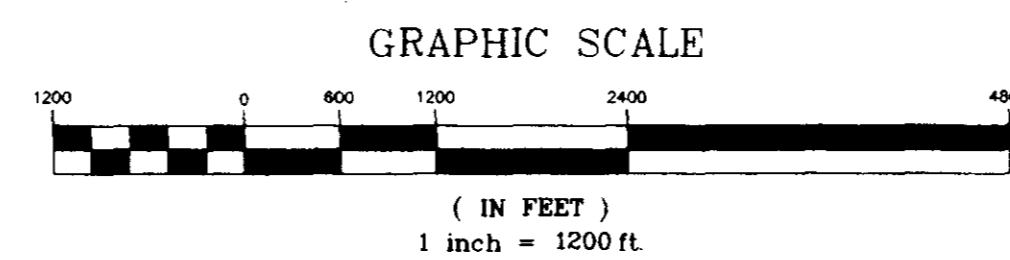

A DEVELOPMENT OF  
SHADOWOOD PARTNERS, INC.

Prepared By:

STERLING  
Consultants

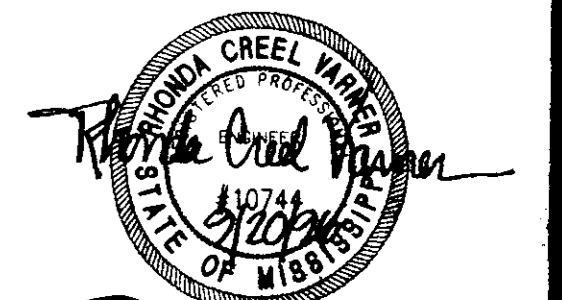

PWPO5029

## MATERIAL REQUIREMENTS

### STREETS

1. CONCRETE FOR CURB AND GUTTER SHALL BE 3,000 PSI MINIMUM.
2. HOT BITUMINOUS PAVEMENT BASE COURSE MIXTURES AND MATERIALS SHALL MEET SPECIFICATION BB-1 OF THE MISSISSIPPI STANDARD SPECIFICATIONS FOR ROAD AND BRIDGE CONSTRUCTION, LATEST EDITION.
3. HOT BITUMINOUS PAVEMENT SURFACE COURSE MIXTURES AND MATERIALS SHALL MEET SPECIFICATION SC-1 OF THE MISSISSIPPI STANDARD SPECIFICATIONS FOR ROAD AND BRIDGE CONSTRUCTION, LATEST EDITION.

### STORM DRAINAGE

1. PIPE - REINFORCED CONCRETE PIPE, ROUND ASTM C-76 OR ARCH, ASTM C-506.
2. JOINTS - O-RING RUBBER GASKETS, BITUMINOUS PLASTIC CEMENT OR PRE FORMED JOINT COMPOUND.
3. INLETS AND JUNCTION BOXES - PRE CAST CONCRETE, ASTM C-478 OR CONCRETE CAST-IN-PLACE. (CITY OF RIDGELAND STANDARD)
4. INLET CASTINGS - VULCAN RCB-7 OR EQUAL AS APPROVED BY ENGINEER.

### WATER

- MAIN - DUCTILE IRON, CEMENT LINED MORTAR PRESSURE CLASS 350 - ANSI/AWWA C151/A21.5.
- ENCASEMENT - POLYETHYLENE FILM ANSI/AWWA A21.5/C105.
- JOINTS - TYLON JOINTS WITH RUBBER GASKET ANSI/AWWA STANDARDS.
- FITTINGS - DUCTILE IRON, COMPACT FITTINGS MECHANICAL JOINT - ANSI/AWWA C153/A21.53-88.
- VALVES - DUCTILE IRON METROSEAL 250 RESILIENT SEATED GATE VALVES - AWWA C509.
- VALVE BOXES - CAST IRON, 3 PIECE ADJUSTABLE STAMPED W/ "WATER".
- SERVICE LINE - 1" MINIMUM, TYPE K COPPER, ASTM B88; POLYETHYLENE (PE), AWWA C901; OR POLYBUTYLENE (PB), AWWA C902.
- SVC SADDLE - FORD STYLE 304, OR APPROVED EQUAL.
- CORP. STOPS - MUELLER NO. H-15000 OR APPROVED EQUAL.
- CURB STOPS - MUELLER H-15175 OR APPROVED EQUAL.
- METER BOX - CAST IRON METER BOX W/ FLIP TOP READING COVER.

### SEWER

- MAIN & SERVICE - PVC, SDR-26, ASTM D-3034 OR DUCTILE IRON, PROTECTO 401 CERAMIC EPOXY LINED.
- JOINTS - SLIP ON W/LOCKED-IN RUBBER GASKET, ASTM F-477.
- MANHOLES - PRE CAST CONCRETE, ASTM C-478. COAL TAR EPOXY COATING. REQUIRED ON INTERIOR AND EXTERIOR OF MANHOLE SECTIONS AND ON MANHOLE STEPS.
- PIPE BOOTS - KOR-N-SEAL MOLDED RUBBER CONNECTORS, OR EQUAL.
- FRAME & COVER - CAST IRON, ASTM A-78 OR EQUAL.

## GENERAL NOTES

### STREET

1. STREET SUB GRADE AREAS WHERE EXPANSIVE CLAYS (CH) ARE ENCOUNTERED WITHIN 4' OF FINISHED GRADE SHALL BE UNDERCUT AND BACK FILLED AS REQUIRED TO SEPARATE PAVEMENT FROM EXPANSIVE CLAYS BY A MINIMUM 3 FOOT THICK LAYER OF SELECT SILTY CLAYS (CL) OR SANDY CLAYS (CL) HAVING A LIQUID LIMIT OF LESS THAN 40 AND A PI WITHIN THE RANGE OF 8 TO 20. THE BACK FILL AND FILL MATERIALS SHOULD BE SPREAD IN LOOSE LIFTS HAVING A MAXIMUM THICKNESS OF 9 IN. AND COMPACTED TO NOT LESS THAN 95 PERCENT OF STANDARD PROCTOR MAXIMUM DRY DENSITY (ASTM D 698) AT MOISTURE CONTENTS WITHIN 3 PERCENTAGE POINTS OF THE OPTIMUM MOISTURE CONTENT. STABILITY MUST BE EVIDENT DURING COMPACTION OF EACH LIFT BEFORE ANY SUBSEQUENT LIFTS OF FILL OR BACK FILL MATERIAL ARE ADDED.
2. UNDERCUTTING AND BACK FILLING SHALL EXTEND A MINIMUM OF 2 FEET BEYOND BACK OF CURB.
3. PRIOR TO PLACING ASPHALT BASE MATERIAL, PAVING CONTRACTOR SHALL: 1) FINE-GRADE THE SUB GRADE MATERIAL TO THE PROPER SECTION TO PERMIT PLACEMENT OF THE REQUIRED THICKNESS OF BASE COURSE; 2) COMPACT AND PROOF-ROLL SUB GRADE TO ACHIEVE STABILITY; AND ENSURE REQUIRED SUB GRADE DENSITY HAS BEEN ACHIEVED AND VERIFIED BY SOILS TESTING LABORATORY.

### CURB AND GUTTER

1. CURB AND GUTTER SHALL BE 24" STANDARD (SEE DETAIL).
2. SUB GRADE BENEATH CURB AND GUTTER SHALL BE FINE GRADED AND COMPACTED TO ACHIEVE STABILITY UNDER PRESSURE OF THE REAR WHEEL LOADING OF A MOTOR GRADER MOVING SLOWLY OVER THE CURB AND GUTTER SUB GRADE.
3. AFTER FORMS AND/OR CURB AND GUTTER STRING LINES HAVE BEEN SET AND BEFORE CONCRETE IS POURED, CONTRACTOR SHALL VERIFY THAT ALL GUTTERS DRAIN TO INLETS.
4. EXPANSION JOINTS IN CURB AND GUTTER SHALL BE 3/4" JOINT MATERIAL PLACED AT 30' (MAXIMUM) INTERVALS.
5. CONTRACTION JOINTS IN CURB AND GUTTER SHALL BE SCORED AT INTERVALS NOT GREATER THAN 10 FEET AND SPACED EQUALLY BETWEEN EXPANSION JOINTS.
6. CONCRETE FOR CURB AND GUTTER SHALL BE 3,000 PSI MINIMUM.
7. 48" SIDEWALKS SHALL BE CONSTRUCTED BY THE BUILDER ON EACH LOT AFTER ALL UTILITY SERVICES ARE INSTALLED AND THE SITE HAS BEEN GRADED AND SHAPED TO ITS FINISHED TOPOGRAPHY. NOT A PART OF THIS PROJECT.

### STORM DRAINAGE & EROSION CONTROL

1. ALL STORM DRAINAGE PIPE AND INLETS SHALL BE FLUSHED AND CLEARED OF ANY CONSTRUCTION MATERIALS AND/OR SEDIMENT UPON PROJECT COMPLETION.
2. THE CONSTRUCTION EXIT SHALL BE MAINTAINED SUCH THAT ALL MATERIALS SPILLED, DROPPED, WASHED OR TRACKED FROM VEHICLES OR SITE ONTO ROADWAYS MUST BE REMOVED IMMEDIATELY.
3. INLET SEDIMENT TRAPS SHALL CONSIST OF HAY BALES FULLY SURROUNDING EACH INLET.
4. SEDIMENT BARRIERS SHALL BE HAY BALES PLACED IN ALL DRAINAGE WAYS TO PREVENT SEDIMENT FROM LEAVING CONSTRUCTION SITE.













### WATER & SEWER

1. ALL WATER AND SANITARY SEWER CONSTRUCTION TO BE IN ACCORDANCE WITH THE CITY OF RIDGELAND STANDARD SPECIFICATIONS.
2. WHERE A SANITARY SEWER MAIN OR SERVICE LINE CROSSES ABOVE A WATER MAIN OR WITHIN 18 INCHES BELOW A WATER MAIN, OR WITHIN 10 FEET ON EITHER SIDE OF A WATER MAIN THE SEWER MAIN OR SERVICE LINE SHALL BE CONSTRUCTED OF DUCTILE IRON.
3. SEWER SERVICE LINES SHALL BE 6"; SEWER MAINS SHALL BE 8" SDR-26 PVC.
4. WATER SERVICE LINES SHALL BE 1"; WATER MAINS SHALL BE 8" PC 350 DI.
5. SERVICES FOR WATER AND SEWER SHALL BE LOCATED NEAR THE CENTER OF ALL LOTS WITH 10 FOOT SEPARATION.
6. BACK FILL OF ALL TRENCHES UNDER EXISTING OR PROPOSED PAVEMENTS AND CURB AND GUTTER SHALL BE MECHANICALLY COMPACTED IN 9" MAXIMUM LOOSE LIFTS TO A MINIMUM OF 95% STANDARD PROCTOR PEAK DRY DENSITY.
7. DEFLECTION TEST SHALL BE PERFORMED ON ALL FLEXIBLE PIPE. THE TEST SHALL BE CONDUCTED AFTER THE FINAL BACK FILL HAS BEEN IN PLACE AT LEAST 30 DAYS. DEFLECTION TEST SHALL BE RUN USING A RIGID BALL OR MANDREL HAVING A DIAMETER EQUAL TO 95% OF THE INSIDE DIAMETER OF THE PIPE. THE TEST SHALL BE PERFORMED WITHOUT MECHANICAL PULLING DEVICES.
8. WATER MAINS SHALL BE INSTALLED WITH 4' MINIMUM COVER UNDER ROADWAY SECTIONS AND 3' MINIMUM COVER ELSEWHERE.
9. CONTRACTOR SHALL MAINTAIN RECORDS DURING CONSTRUCTION OF HORIZONTAL AND VERTICAL LOCATION OF ALL WATER AND SEWER SERVICES FOR AS BUILT RECORDS.

## INDEX TO DRAWINGS

- 1 COVER SHEET
- 2 GENERAL NOTES AND INDEX TO DRAWINGS
- 3 STREETS & LOT LAYOUT
- 4 WATER & SEWER LAYOUT
- 5 STORM DRAINAGE LAYOUT
- 6 PLAN AND PROFILE - WENDOVER DRIVE  
STA. -1+11.83 - STA. 5+65.52
- 7 PLAN AND PROFILE - TURNBERRY LANE  
STA. 0+00 - STA. 12+01.42
- 8 PLAN AND PROFILE - CONCRETE PAVED DITCH  
STA. 0+00 - STA. 13+39.83
- 9 STANDARD MISCELLANEOUS DETAILS
- 10 STANDARD SEWER DETAILS

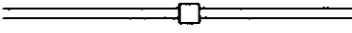
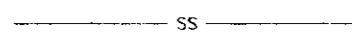
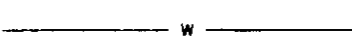
## LEGEND

	PROPERTY LINE
	LOT LINE
	RIGHT OF WAY LINE
	EASEMENT
	SETBACK LINE
	CENTER LINE
	EDGE OF PAVEMENT
	BACK OF CURB
	EXISTING CONTOUR
	PROPOSED SANITARY SEWER & MANHOLE
	PROPOSED STORM SEWER & CATCH BASIN
	SANITARY SEWER
	WATER LINE
	PROPOSED WATER VALVE
	PROPOSED FIRE HYDRANT
	PROPOSED TEE

WENDOVER PART 2A  
A DEVELOPMENT OF  
SHADOWOOD PARTNERS, INC.

## GENERAL NOTES AND INDEX TO DRAWINGS

CITY OF RIDGELAND  
MADISON COUNTY, MISSISSIPPI

DESIGN: RCV	DATE: 07/17/24	STERLING Consultants	DRAWING NO. 2 of 10
DRAWN: RDP	DATE: 07/17/24		
CHECK: RCV	DATE: 07/17/24	SCALE: AS SHOWN	

REVISION BY DATE

Prepared by: David Bates & Sterling Consultants, Inc.  
 Date: 10/14/10

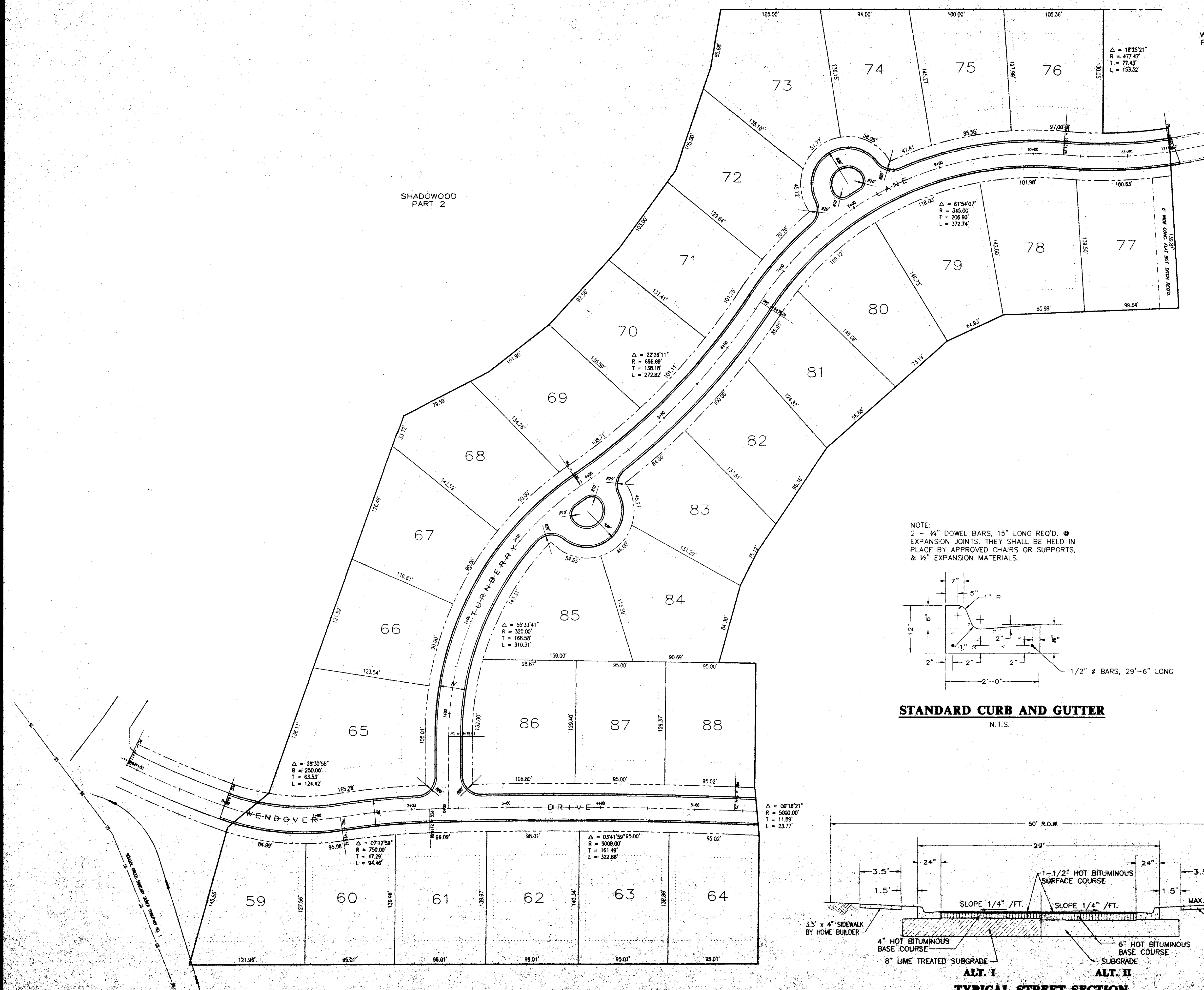

NOTE:  
 2 - 3/4" DOWEL BARS, 15" LONG REQ'D. @  
 EXPANSION JOINTS. THEY SHALL BE HELD IN  
 PLACE BY APPROVED CHAIRS OR SUPPORTS,  
 & 1/2" EXPANSION MATERIALS.

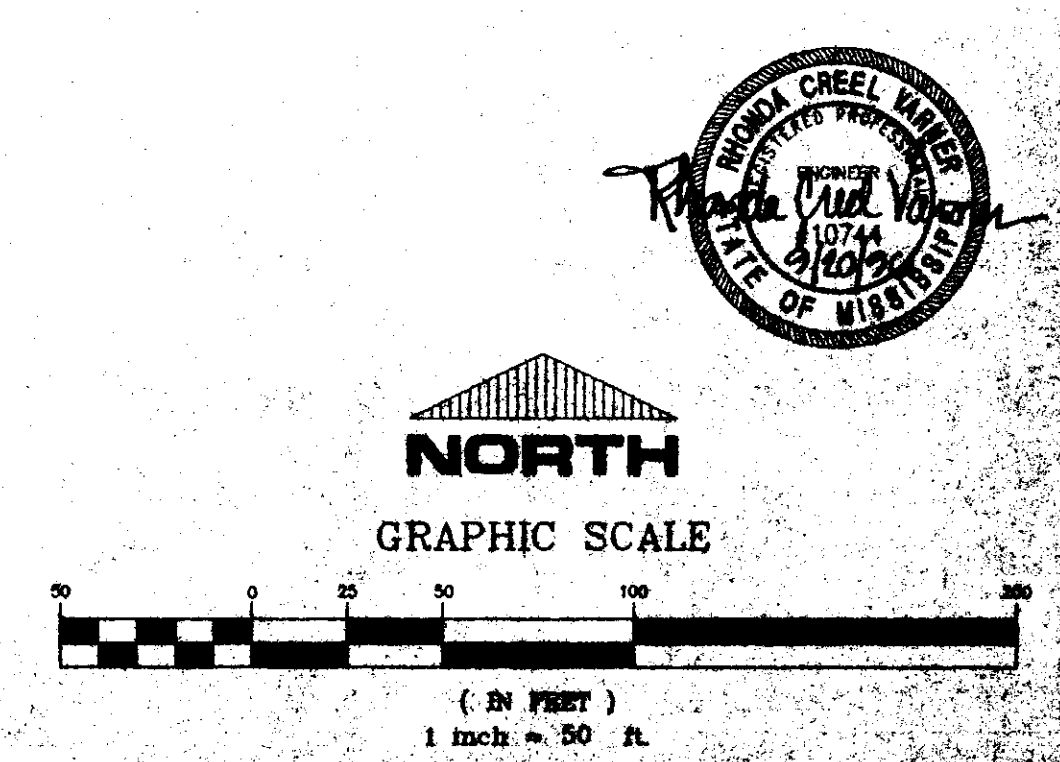
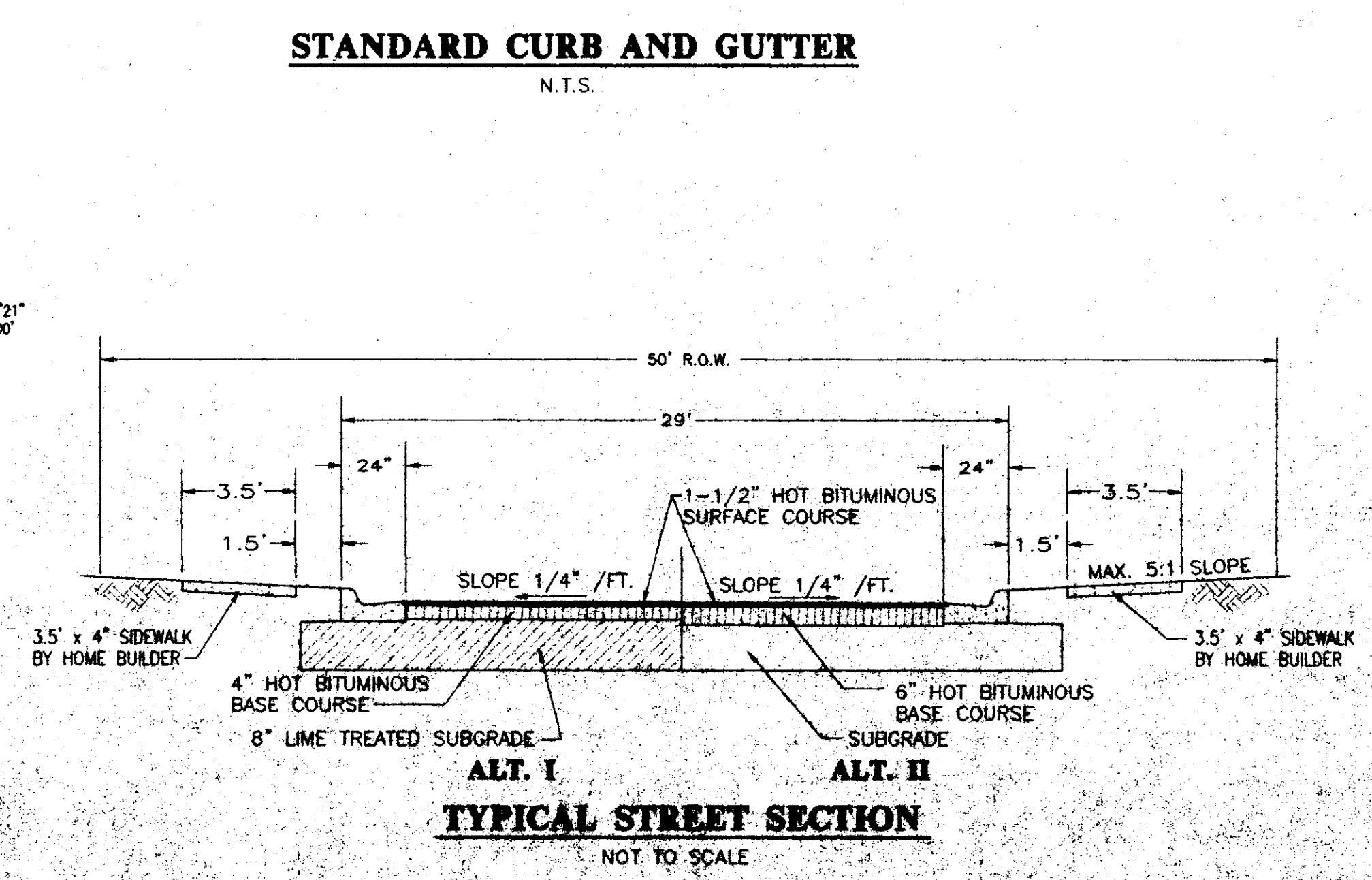
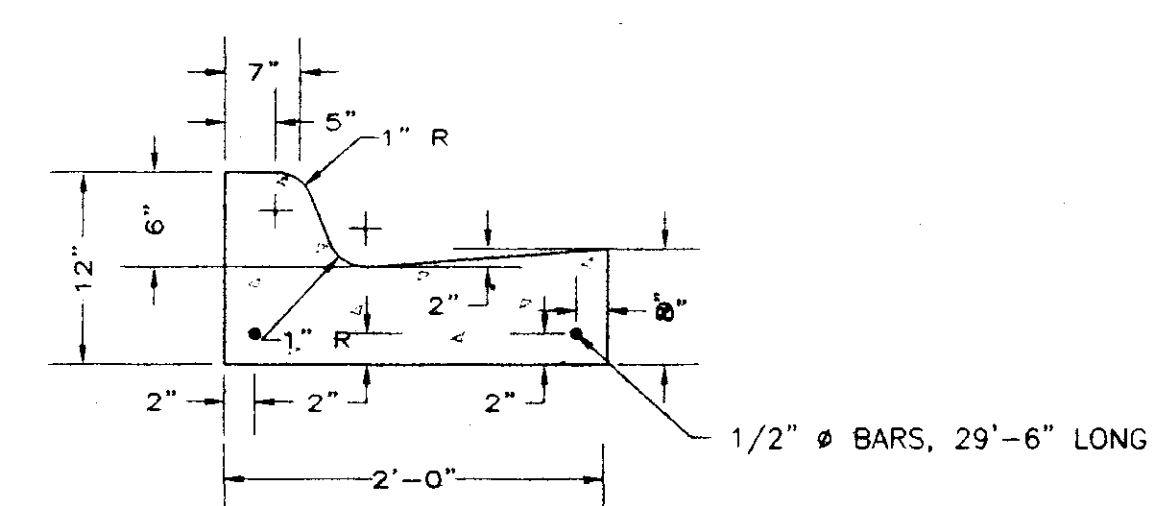

WENDOVER PART 2A  
 A DEVELOPMENT BY  
 SHADOWOOD PARTNERS, INC.

STREETS & LOT  
 LAYOUT

CITY OF RIDGELAND  
 MADISON COUNTY, MISSISSIPPI

REV. DATE  
 10/14/10

STERLING  
 CONSULTANTS, INC.

3 - 10

City of Ridgeland, MS, 2010, 47.57.1996 R. David Bates - Sterling Consultants, Inc.

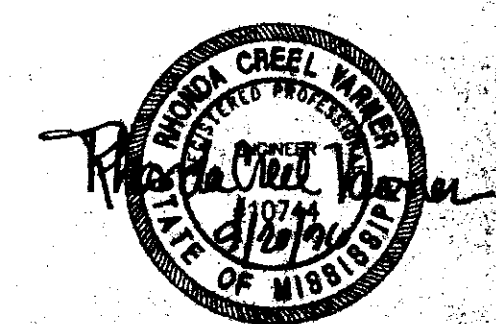
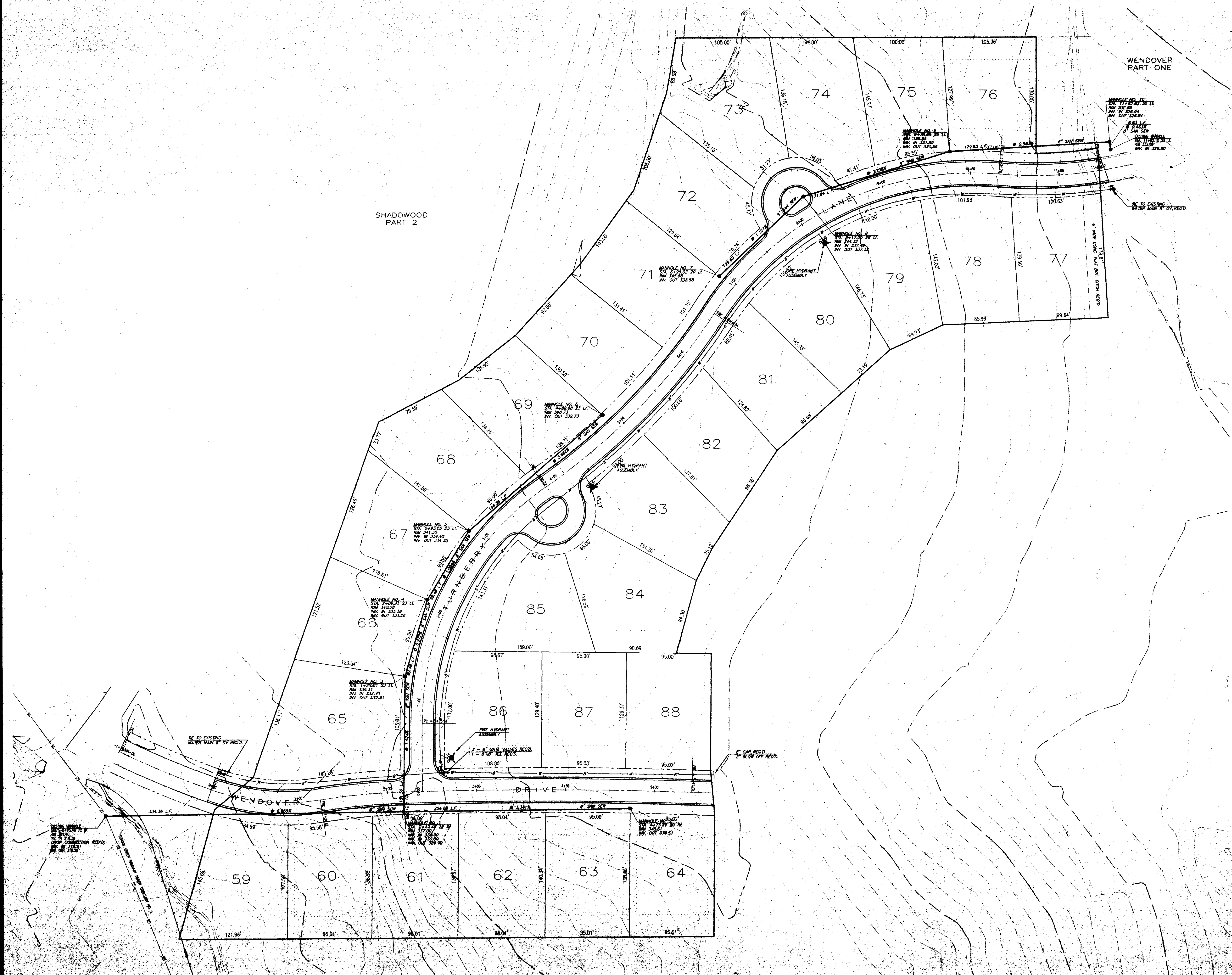

**NORTH**  
GRAPHIC SCALE

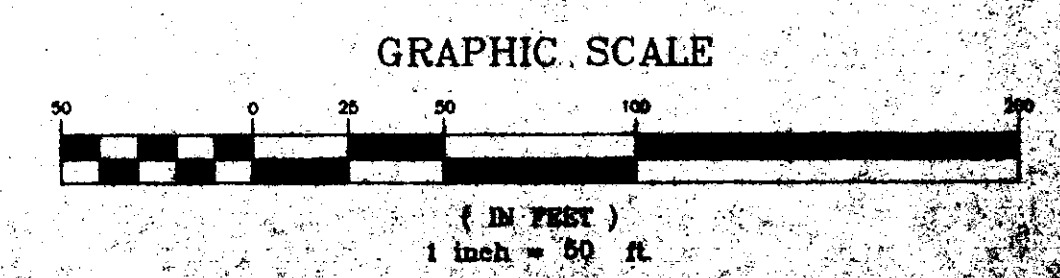

**WENDOVER PART 2A**  
**A DEVELOPMENT BY**  
**SHADOWOOD PARTNERS, INC.**

**WATER & SEWER**  
**LAYOUT**

**CITY OF RIDGELAND**  
**MADISON COUNTY, MISSISSIPPI**

DATE	REV	BY	APP
01/17/10	1	MB	MB
02/17/10	2	MB	MB
03/17/10	3	MB	MB

STERLING  
Consultants



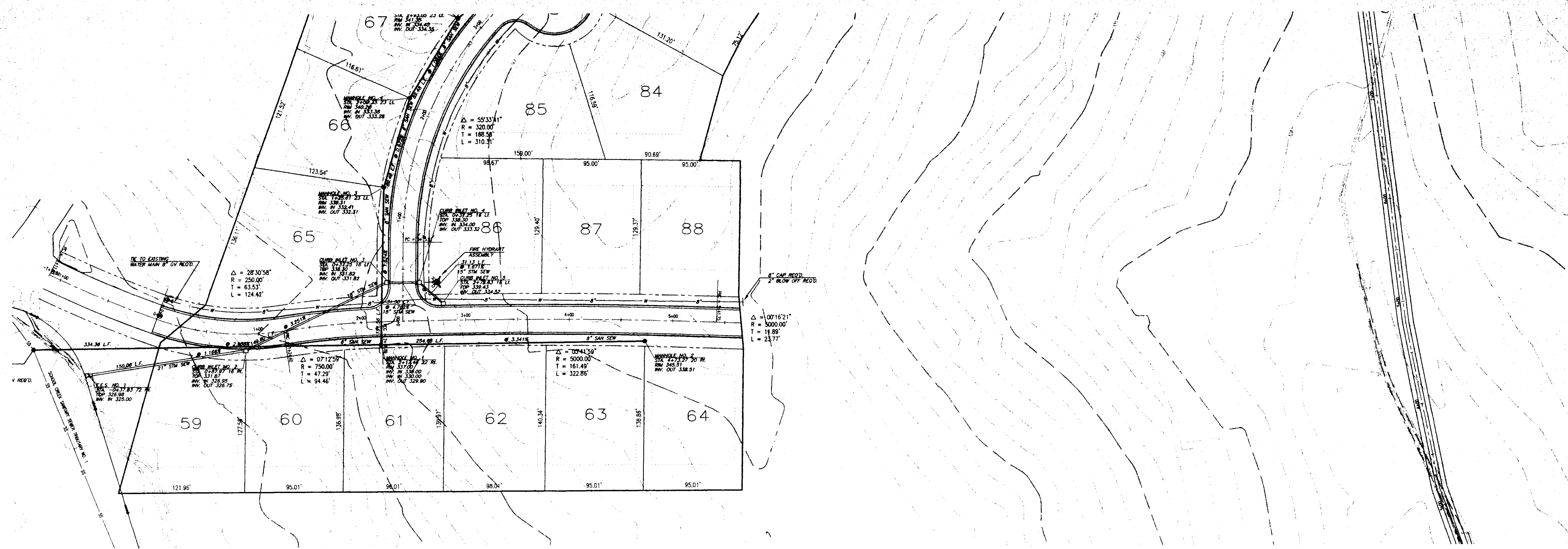

SCALE 1"=50' HORIZ.  
1"= 5' VERT.

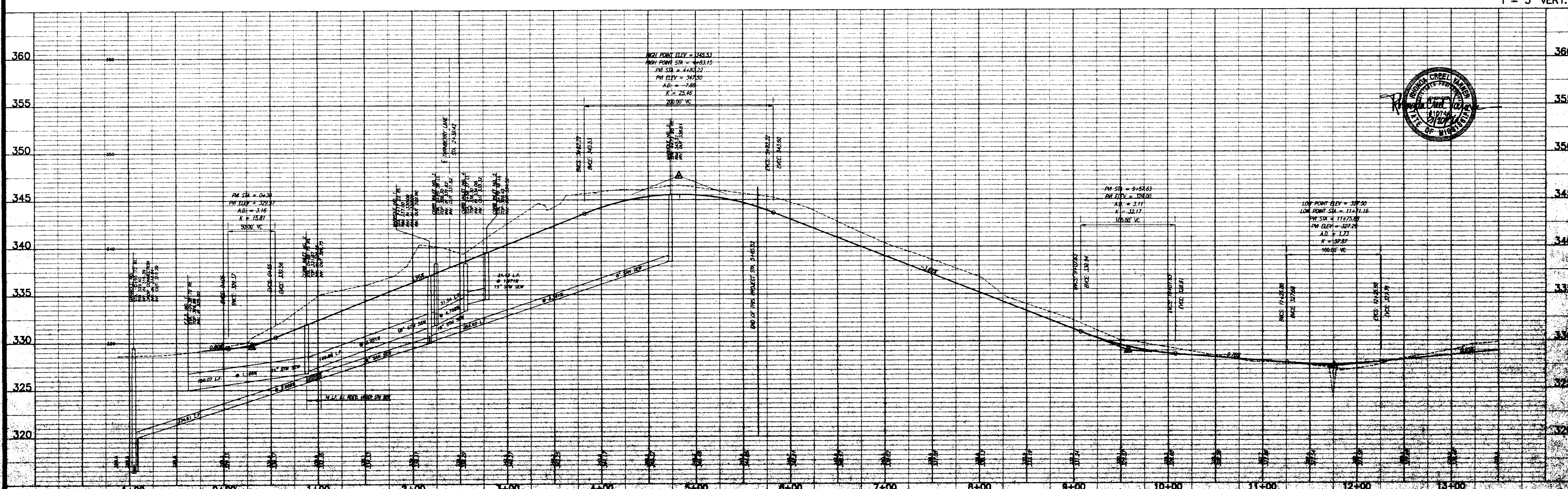

WENDOVER PART 2A  
CITY OF RIDGLAND  
MADISON COUNTY, MISSISSIPPI

PLAN AND PROFILE - WENDOVER DRIVE  
STA. -1+11.83 - STA. 5+65.52

Prepared For:  
SHADOWOOD PARTNERS, INC.

Checked By: RGV  
Drawn By: RPA  
Scale: 1"=50' HORIZ.  
1"=5' VERT.

DATE: 07/12/06  
DATE: 07/12/06  
DATE: 07/12/06

STERLING  
6-10

WORKSHEET NUMBER: 001 Tue Sep 17 11:45:21 1996 R. David Bates - Sterling Consultants, Inc.

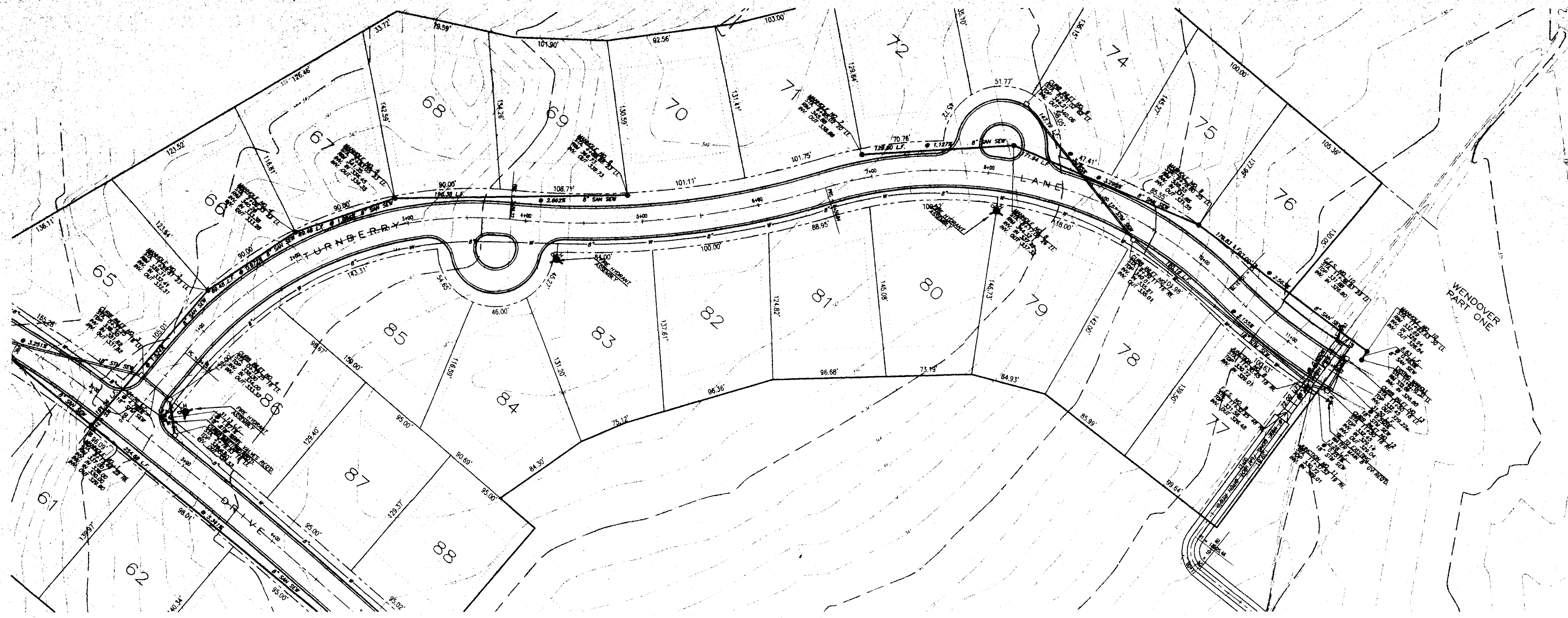

SCALE 1"=50' HORIZ.  
1"= 5' VERT.

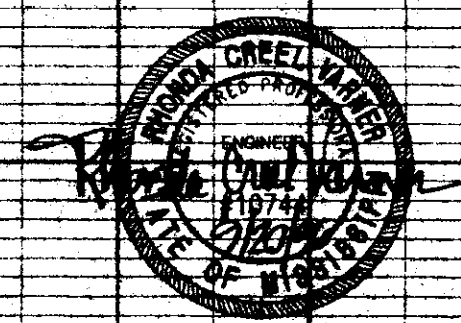
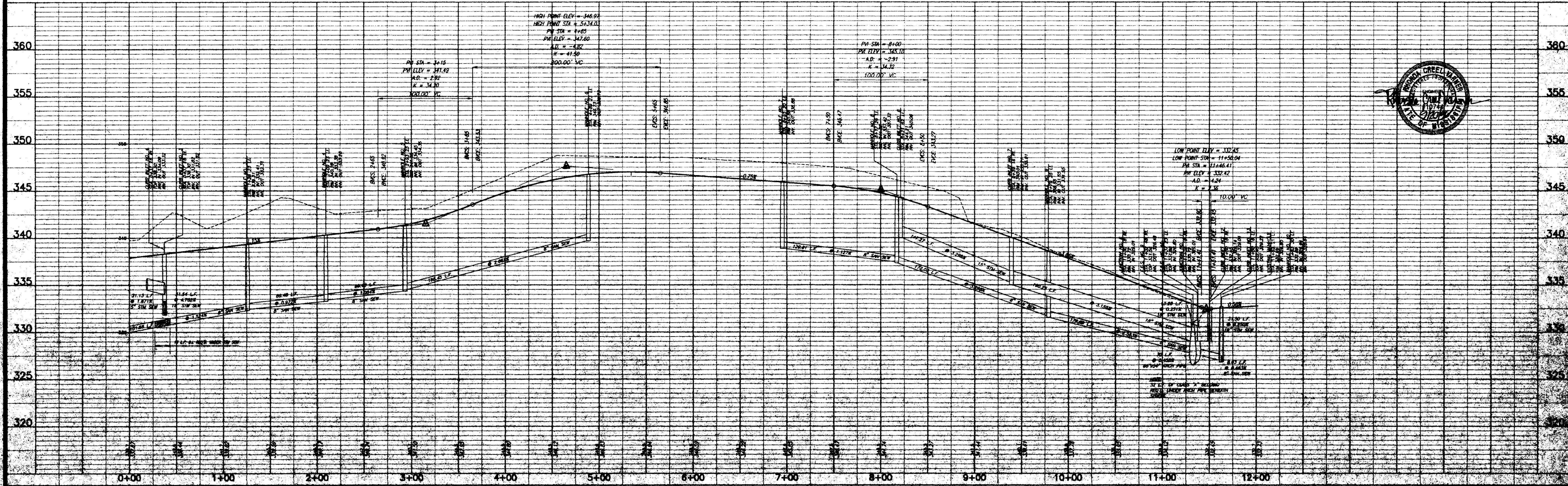

WENDOVER PART 2A  
CITY OF RIDGELAND  
MADISON COUNTY, MISSISSIPPI

PLAN AND PROFILE - TURNBERRY LANE  
STA. 0+00 - STA. 12+01.42

Prepared For:  
SHADOWOOD PARTNERS, INC.

Project No. RGV Date 05/11/14  
Drawn By: RDB Date 05/11/14  
Checked By: RGV Date 05/11/14  
Title: TURNBERRY LANE  
Drawing No. 7-10

© 2014 David Bates & Associates, Inc. David Bates - Sterling Consultants, Inc.

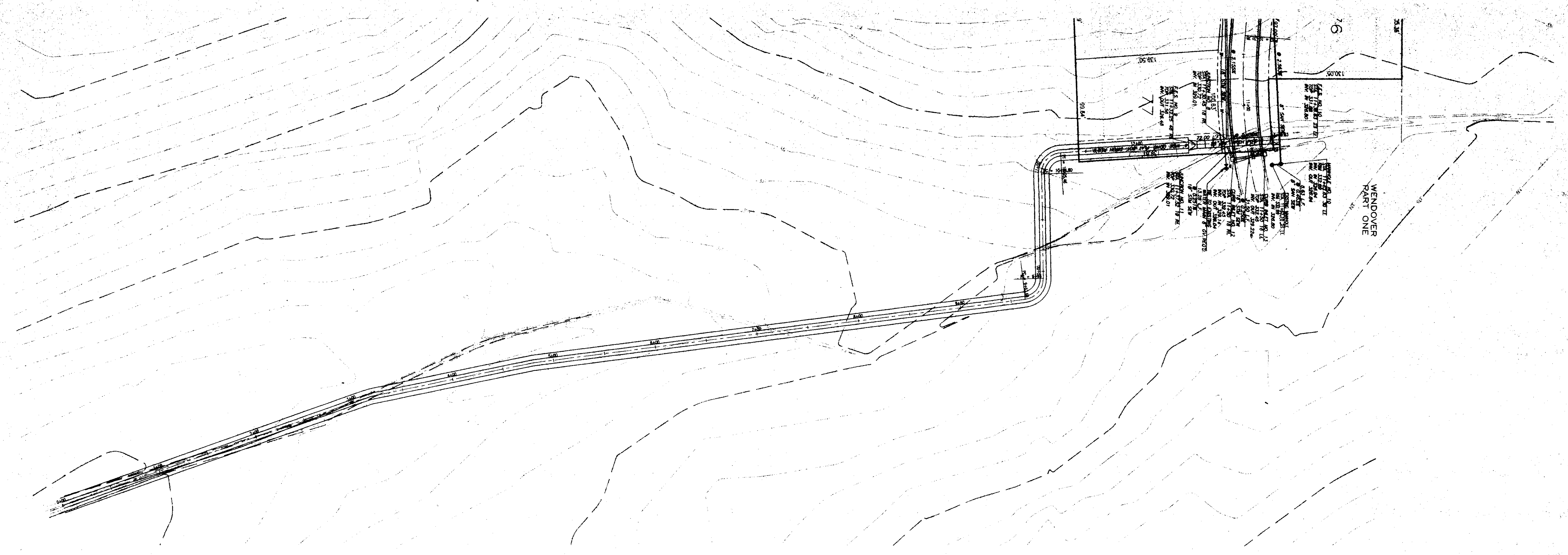

SCALE 1" = 50' HORIZ.  
1" = 5' VERT.

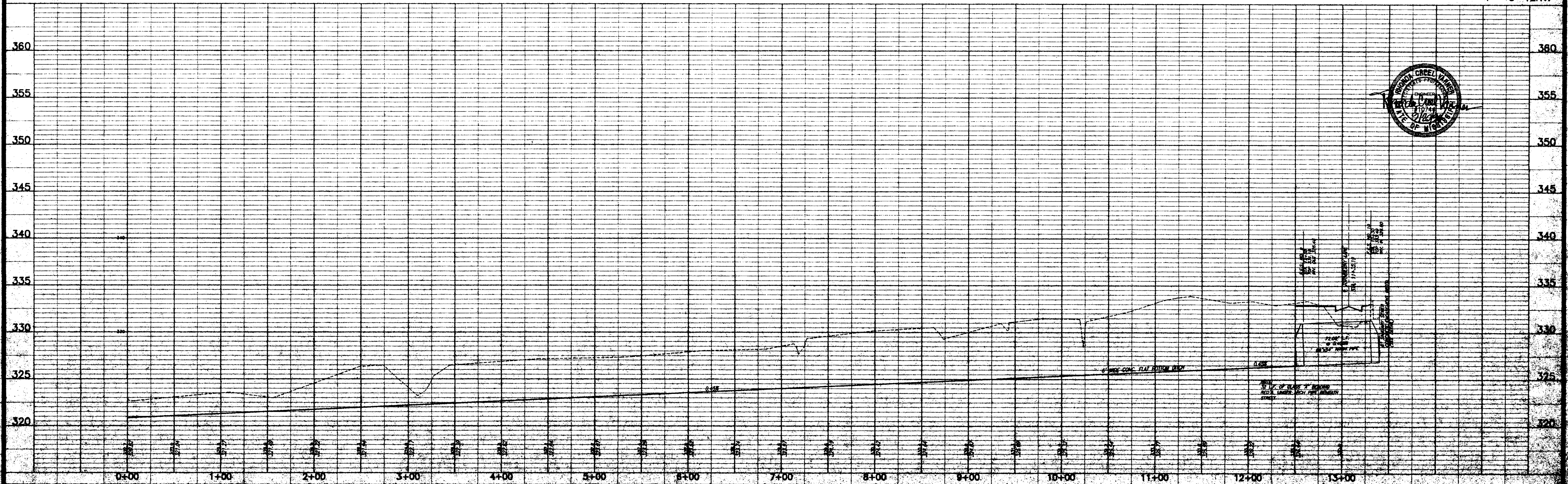

WENDOVER PART 2A  
CITY OF RIDGELAND  
MADISON COUNTY, MISSISSIPPI

PLAN AND PROFILE - CONCRETE PAVED DITCH  
STA. 0+00 - STA. 13+39.83

Prepared For  
SHADOWWOOD PARTNERS, INC.

Checked By	REV	DATE
Drawn By	REV	DATE
Checked By	REV	DATE
Date	REV	DATE

STERLING  
8 x 10

C:\Users\jw\Documents\Wendover\Wendover.dwg, Fri Sep 26 11:03:47 1996, R. David Bates - Sterling Consultants, Inc.



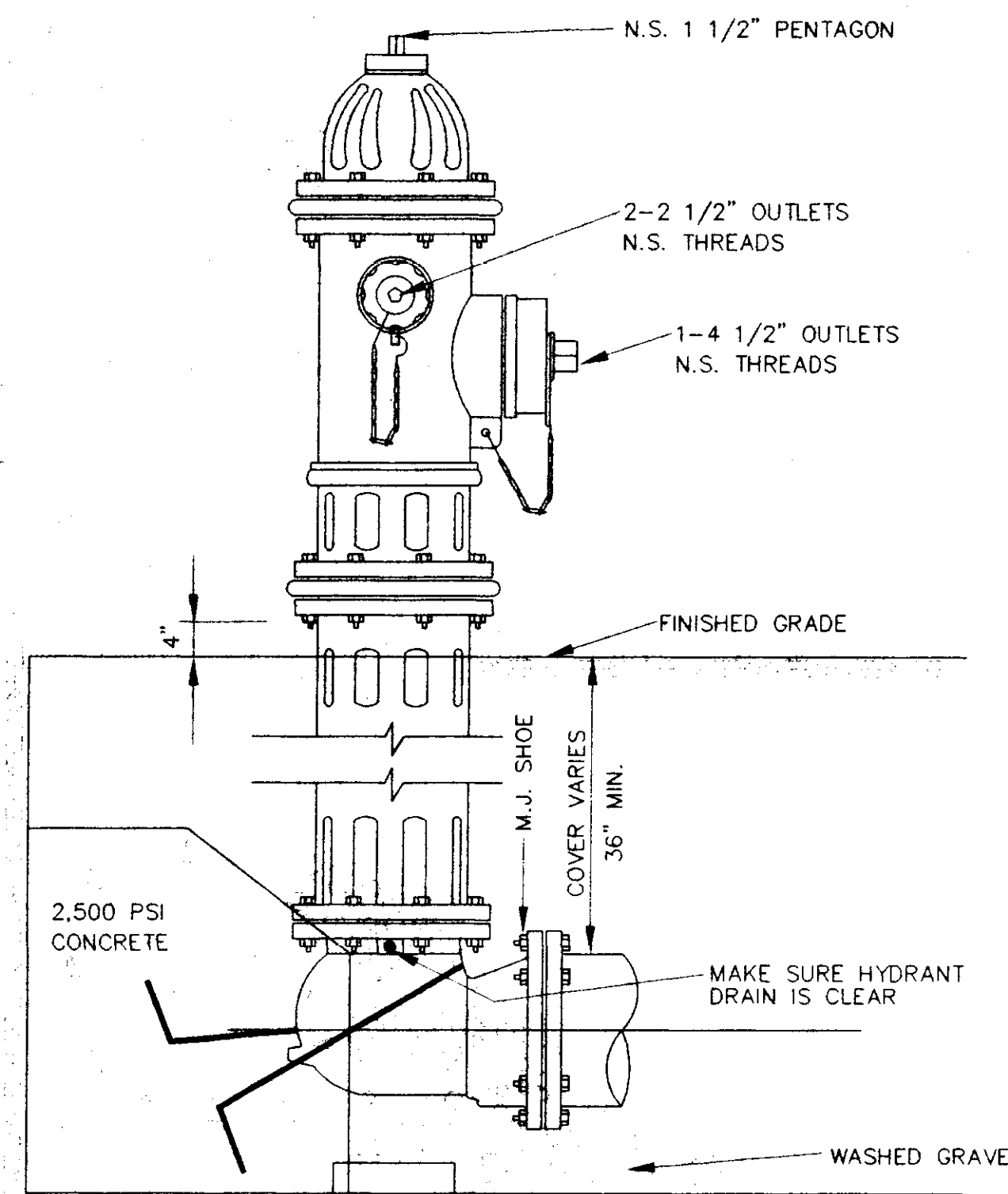

**ELEVATION**

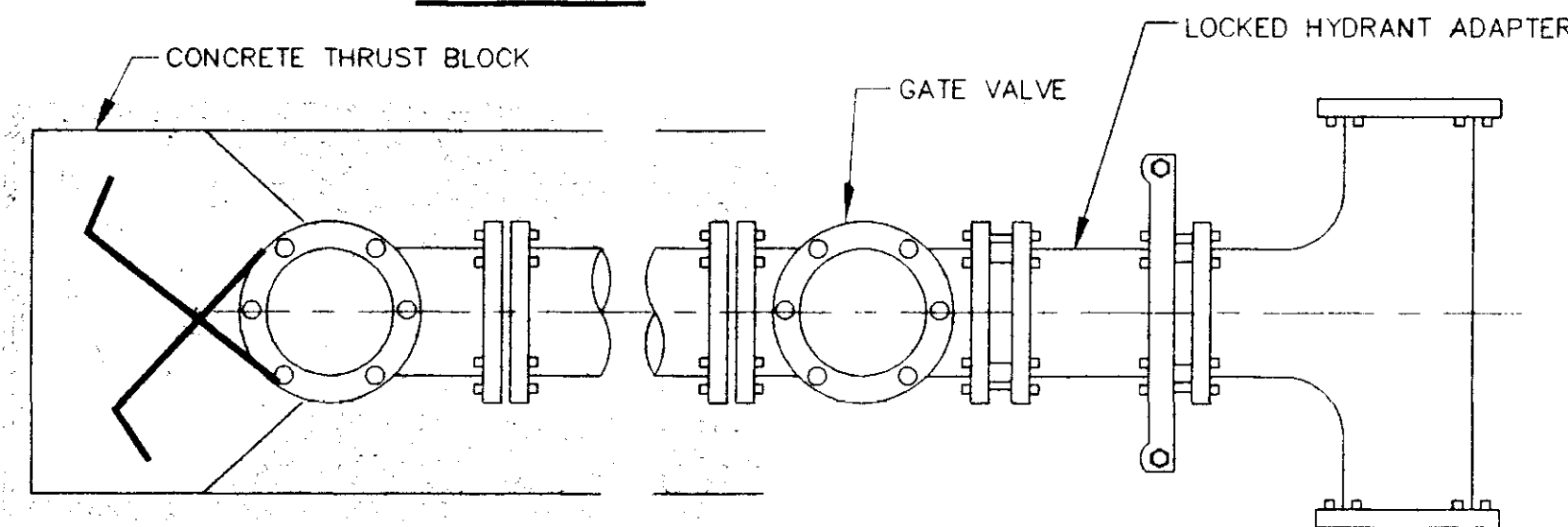

**PLAN**

**TYPICAL FIRE HYDRANT INSTALLATION**

NOTE: GATE VALVES WILL BE REQUIRED ON ALL FIRE HYDRANT LEGS.  
N.T.S.

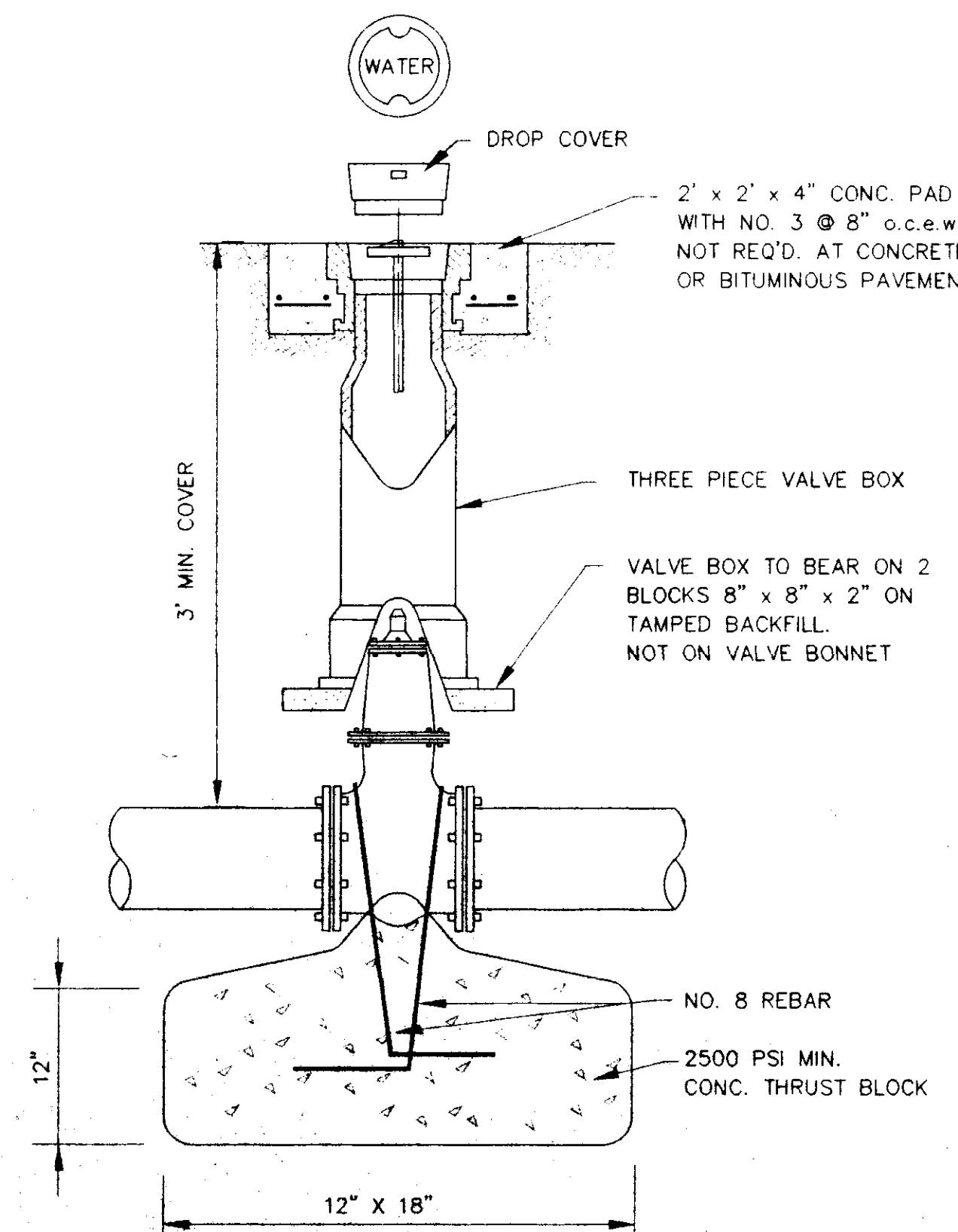

**GATE VALVE DETAIL**

NOT TO SCALE

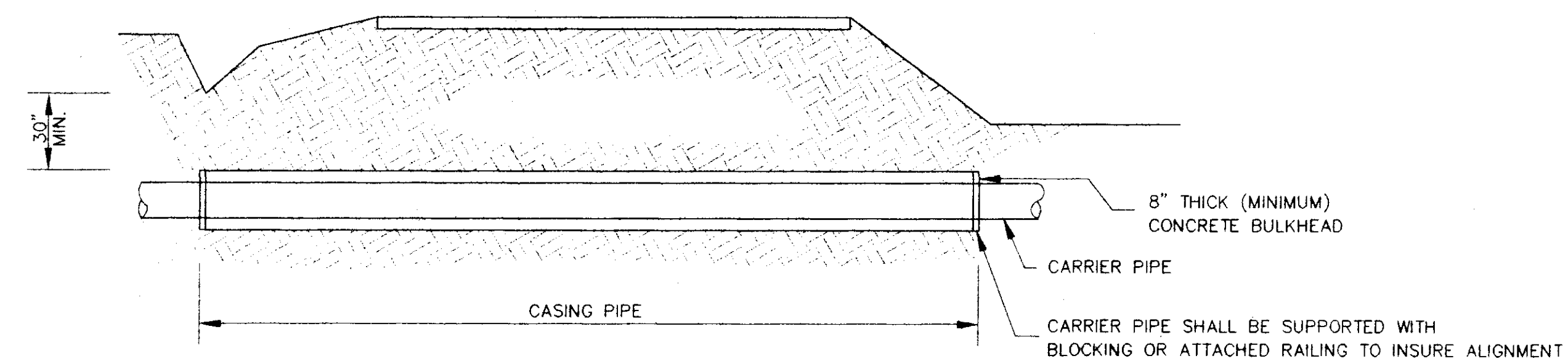

**TYPICAL BORE SECTION**

NOT TO SCALE

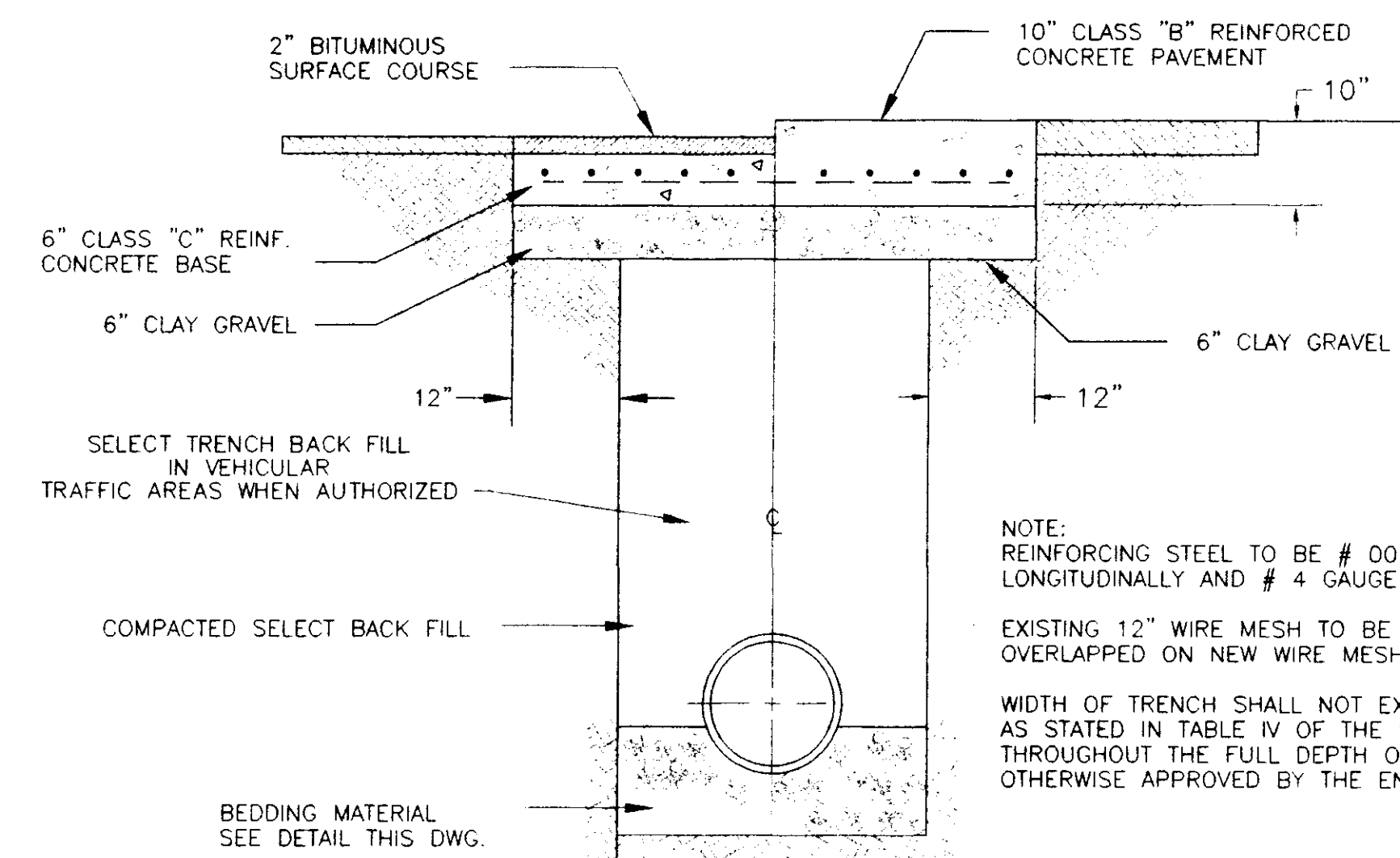

**TYPICAL ROADWAY SECTION**

NOT TO SCALE

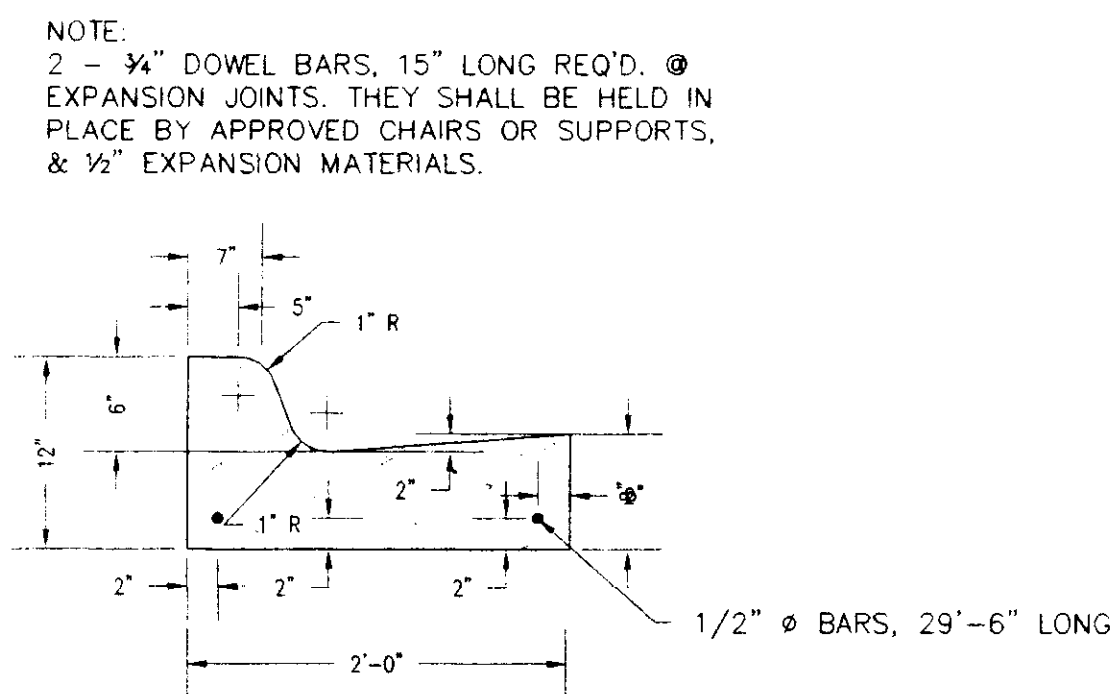

**STANDARD CURB AND GUTTER**

N.T.S.

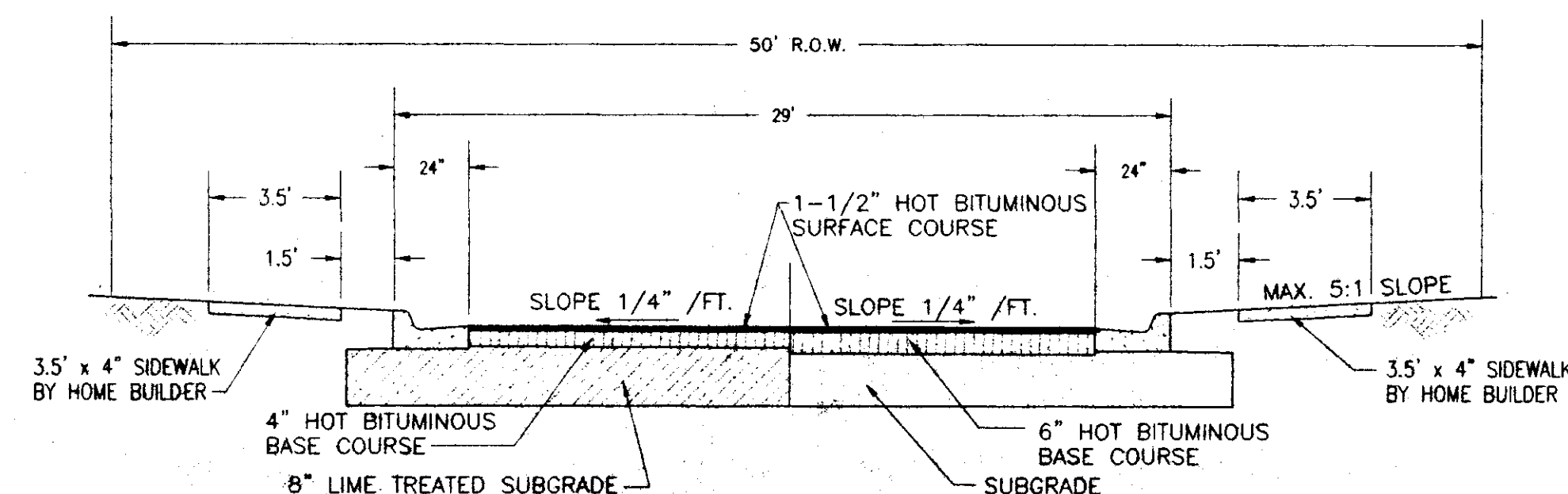

**TYPICAL STREET SECTION**

NOT TO SCALE

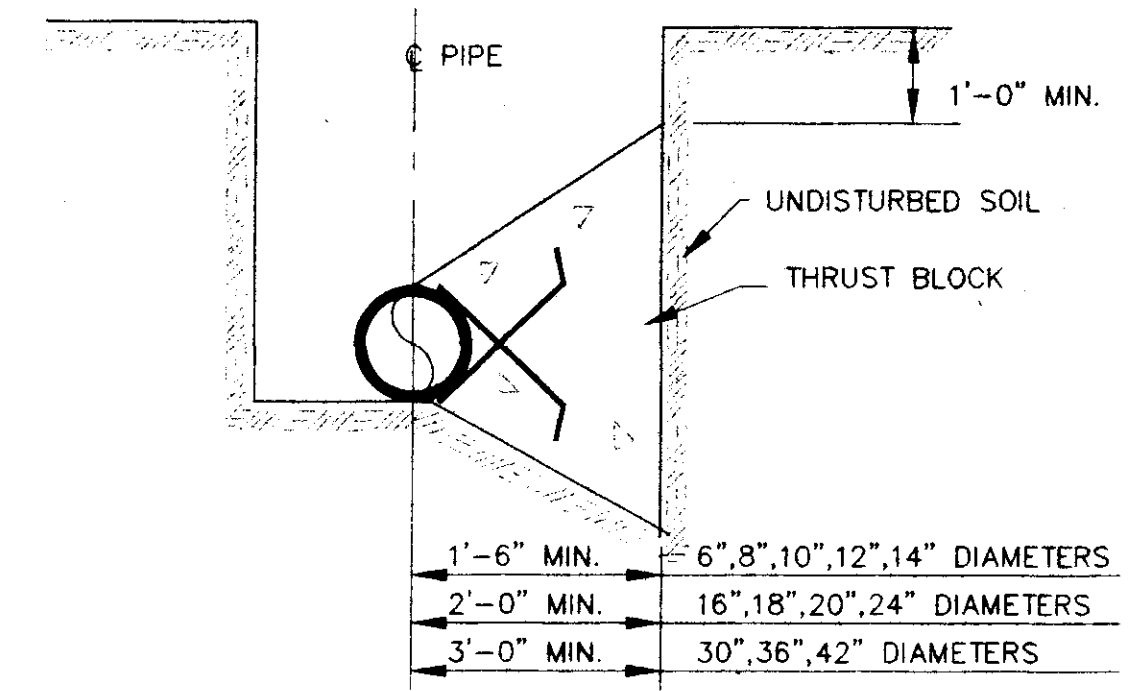

**TYPICAL CROSS SECTION**

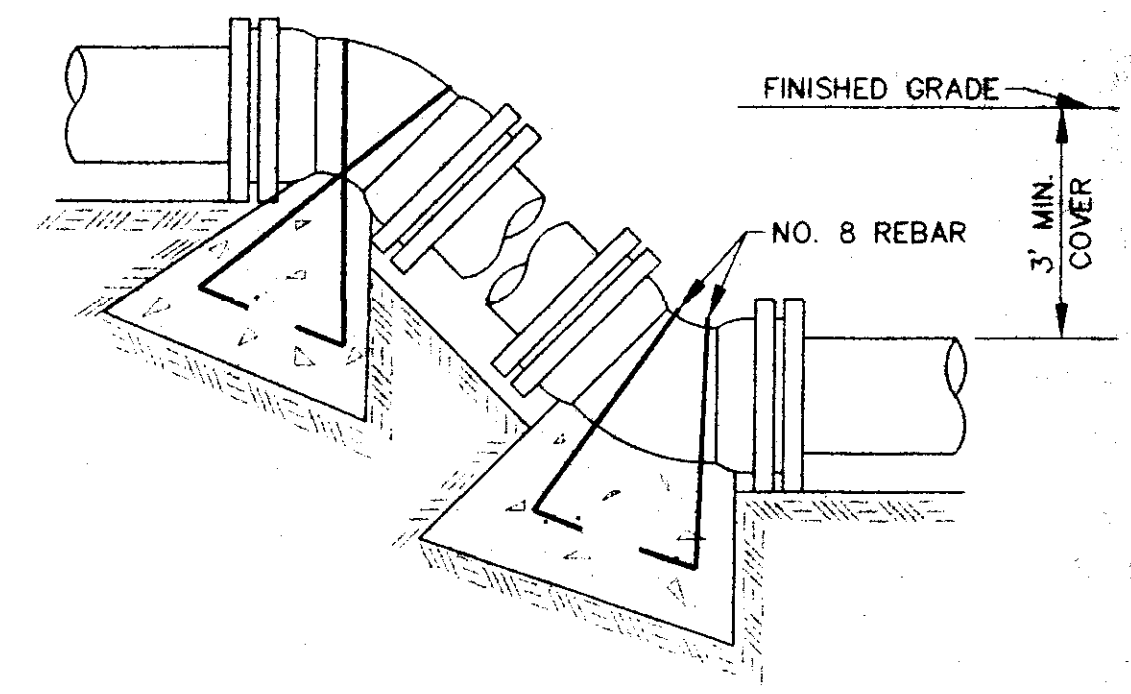

**VERTICAL BENDS**

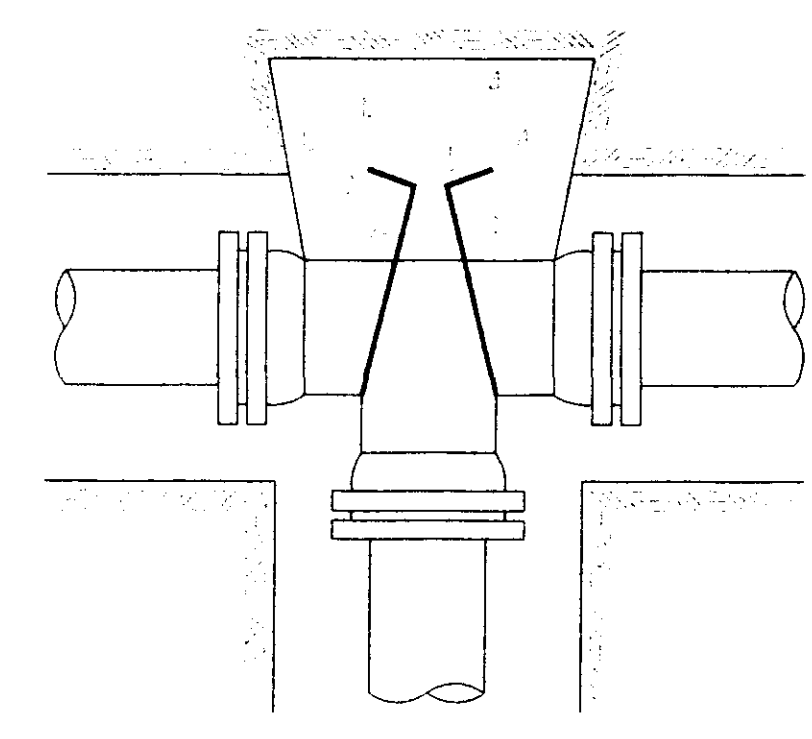

**TEE**

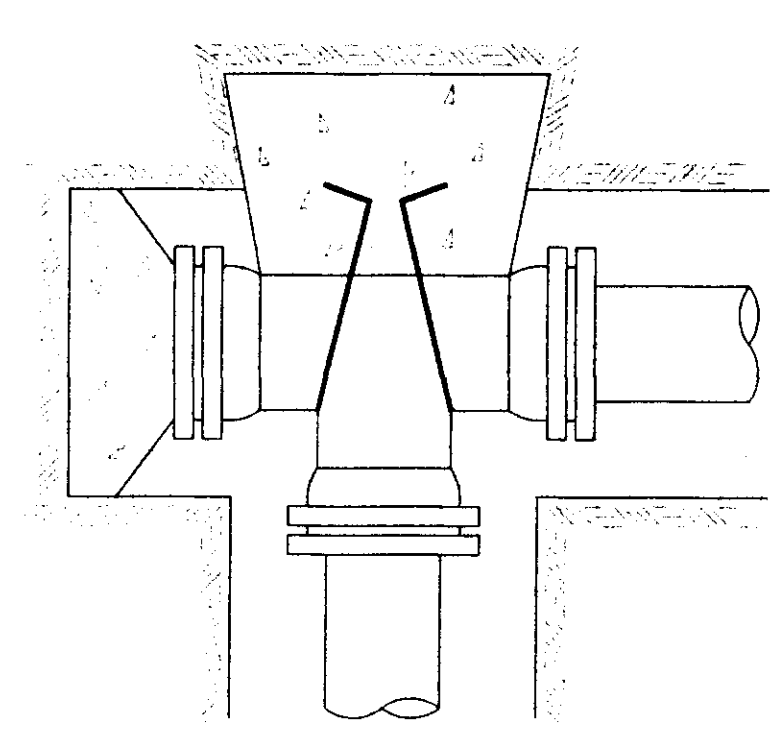

**PLUGGED TEE**

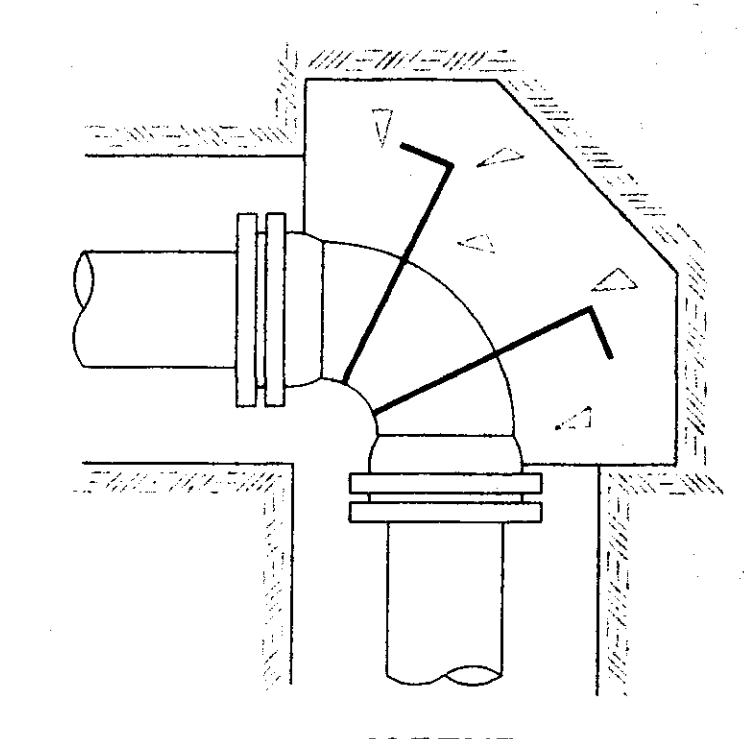

**90 BEND**

**TYPICAL THRUST BLOCKING IN WATER MAINS AND SEWAGE FORCE MAINS**

NOT TO SCALE  
NOTE: ALL THRUST BLOCKS 2,500 PSI CONCRETE AGAINST UNDISTURBED EARTH

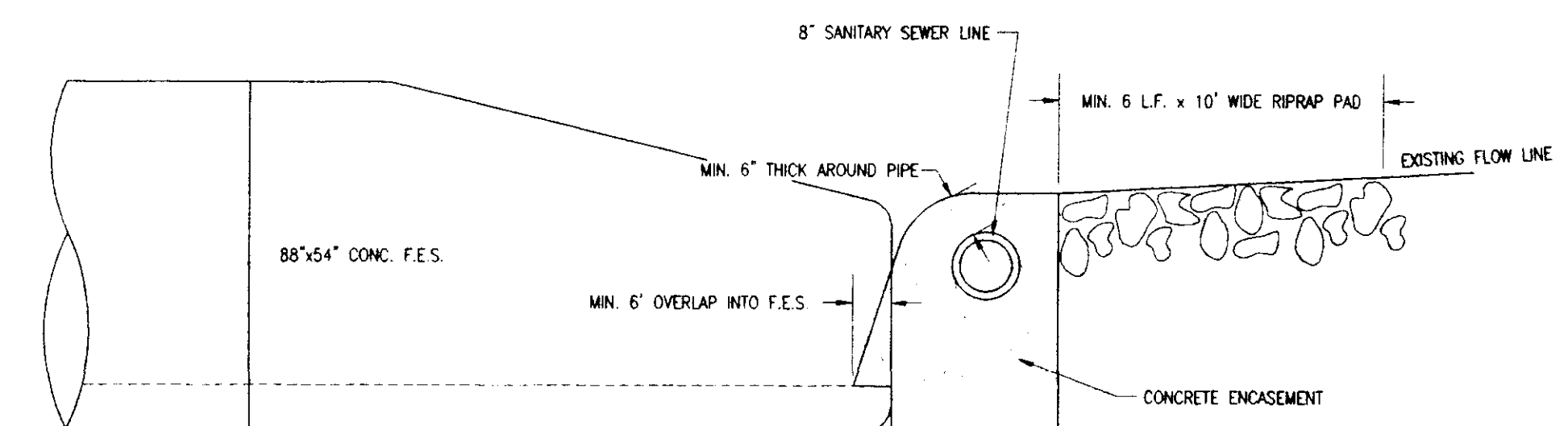

**DETAIL OF CONCRETE ENCASUREMENT OF SANITARY SEWER AT UPSTREAM END OF 88"x54" ARCH PIPE**

NOT TO SCALE

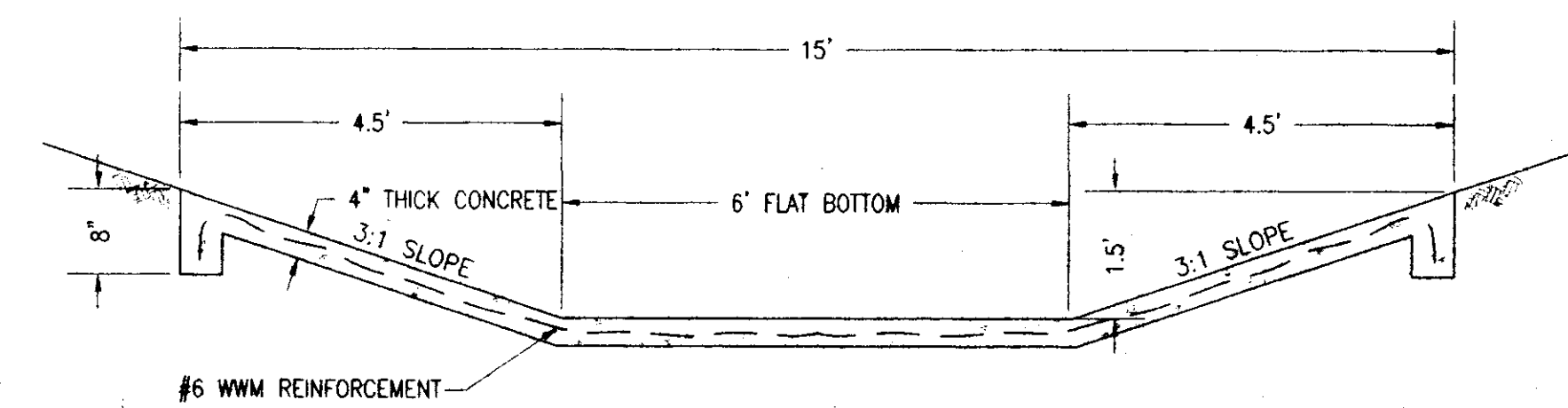

**TYPICAL CONCRETE PAVED DITCH SECTION**

NOT TO SCALE

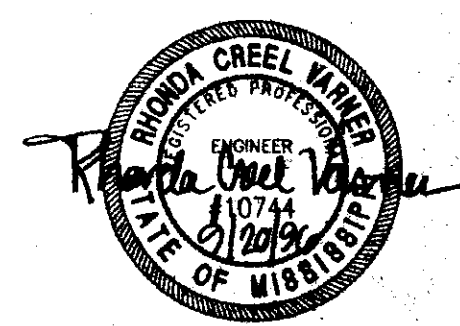

**WENDOVER PART 2A  
A DEVELOPMENT OF  
SHADOWOOD PARTNERS, INC.**

**STANDARD  
MISCELLANEOUS DETAILS**

**CITY OF RIDGELAND  
MADISON COUNTY, MISSISSIPPI**

DESIGN: RCV	DATE: 02/11/24	<b>STERLING Consultants</b>	DRAWING NO. <b>9 of 10</b>
DRAWN: RDB	DATE: 02/11/24		
CHECK: RCV	DATE: 02/11/24		
SCALE: AS SHOWN			

C:\prow\prow\WENDOVER-004 Fri Sep 20 10:23:03 1996 R. David Bates - Sterling Consultants, Inc

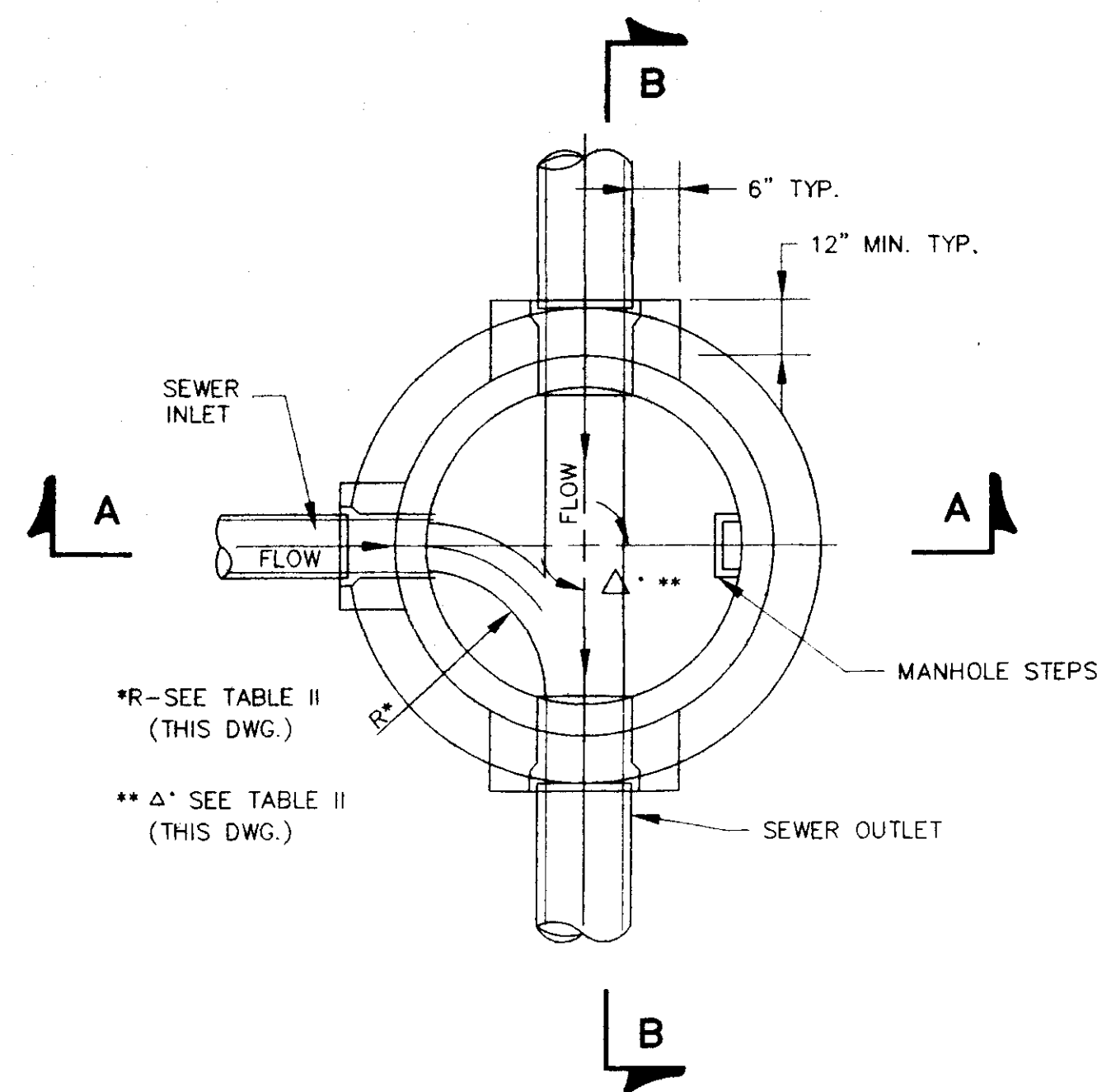

**SECTIONAL PLAN  
STANDARD MANHOLE**  
NOT TO SCALE

TABLE II  
GOVERNING DIMENSIONS FOR MANHOLES

PIPE SIZE	Δ ANGLE	BASE DIAMETER **	"R" *
8" THRU 12"	0° TO 90°	4'	1'-6"
15"	0° TO 60°	4'	1'-10"
15"	60° TO 90°	4'	1'-10"
18"	0° TO 60°	4'	2'-3"
18"	60° TO 90°	4'	1'-10"
21"	0° TO 60°	4'	2'-7"
21"	60° TO 90°	5'	2'-4"
24"	0° TO 45°	4'	3'-0"
24"	45° TO 90°	5'	2'-3"
30"	0° TO 60°	5'	3'-9"
30"	60° TO 90°	6'	2'-8"
36"	0° TO 60°	6'	4'-6"
36"	60° TO 90°	7'	3'-11"
42"	0° TO 60°	7'	5'-3"
42"	60° TO 90°	8'	4'-7"
48"	0° TO 60°	8'	6'-0"
48"	60° TO 90°	9'	5'-3"

\* SEE SECTIONAL PLAN, STANDARD MANHOLE  
\*\* PRECAST MANHOLE

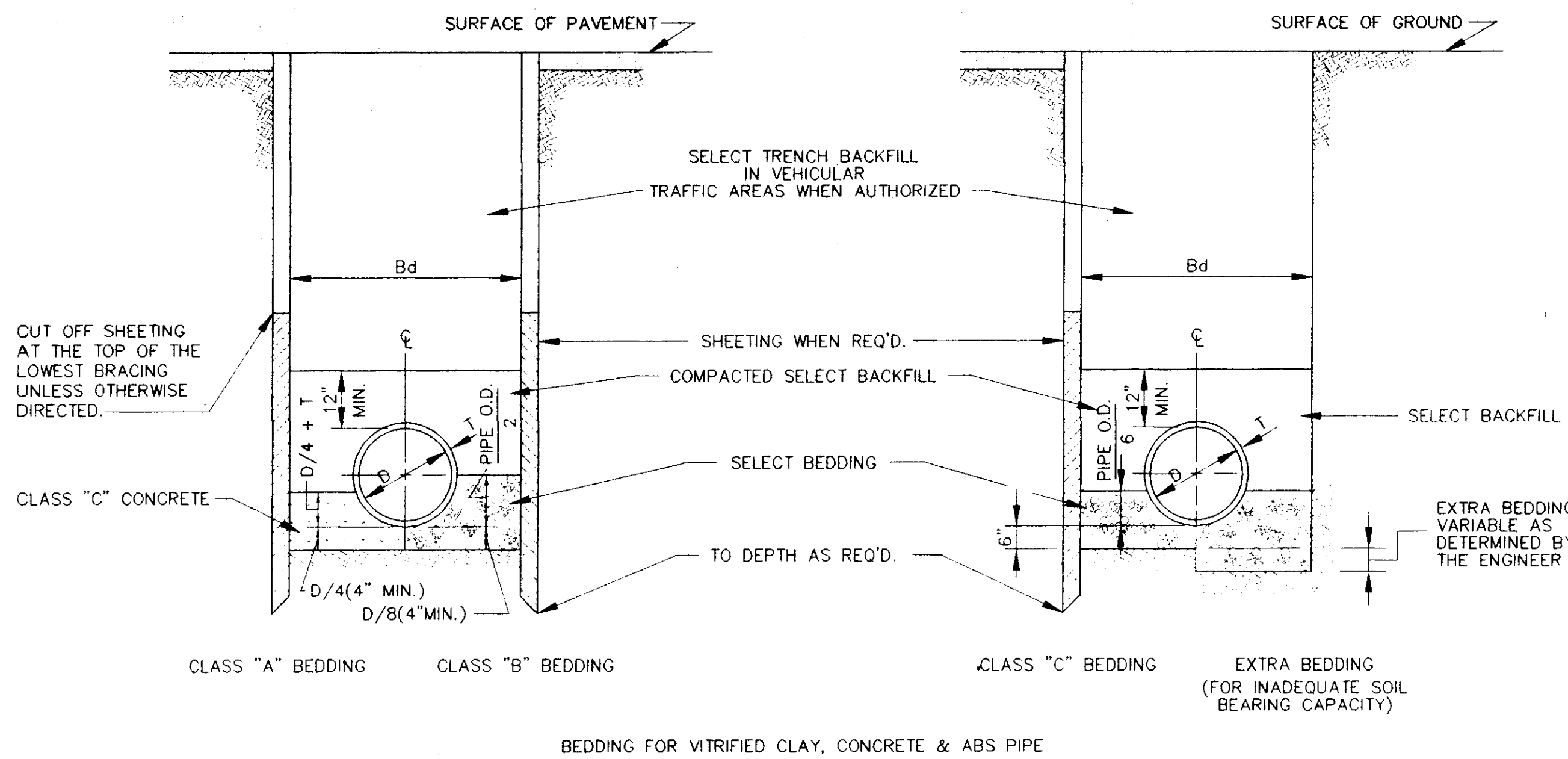

**TYPICAL TRENCH DETAILS**  
NOT TO SCALE

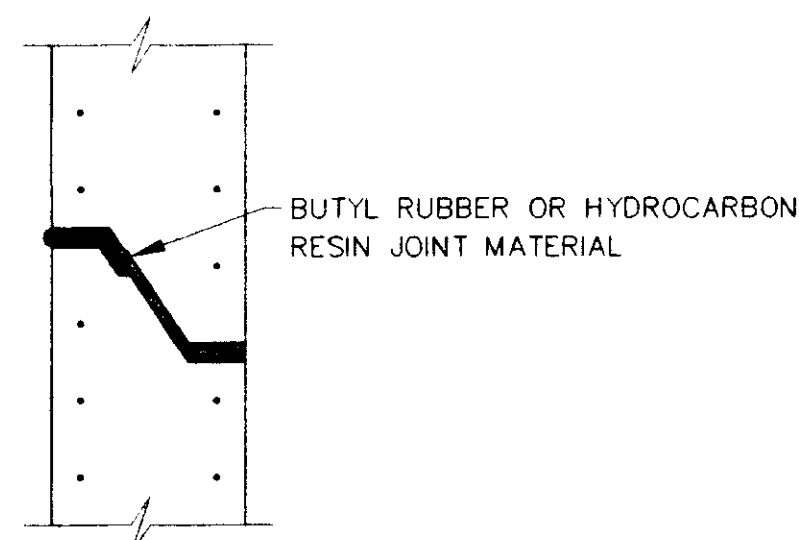

**TYPICAL PRECAST CONCRETE  
MANHOLE JOINT DETAIL**  
N.T.S.

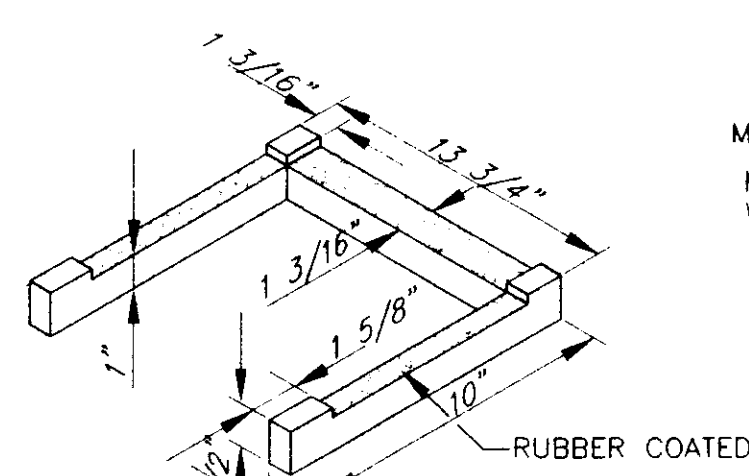

**MANHOLE STEP DETAIL**  
NOT TO SCALE

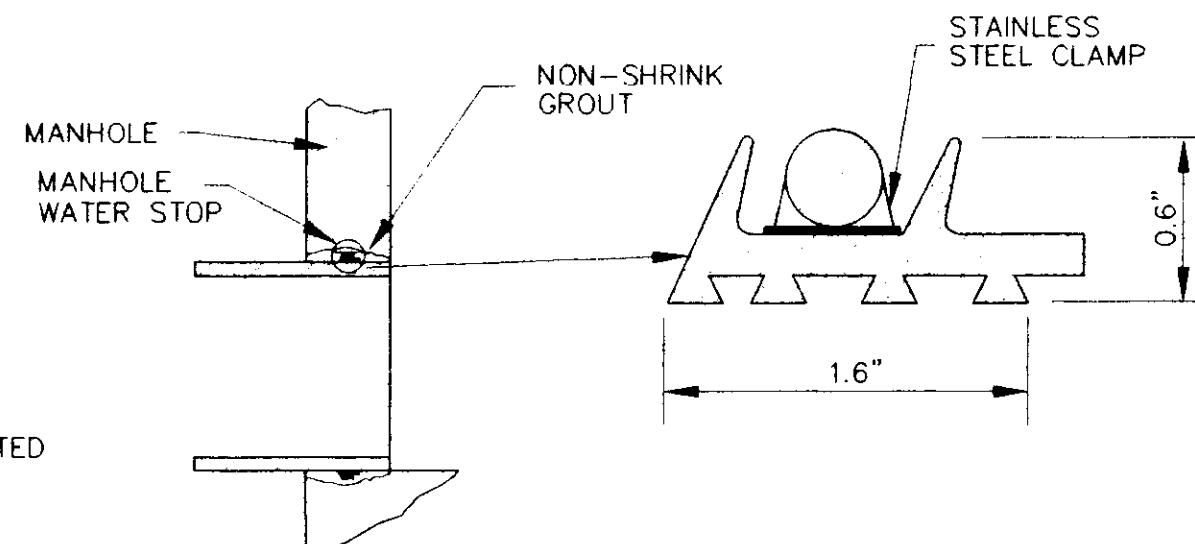

**TYPICAL MANHOLE WATER STOP  
FOR ABS, CLAY OR PVC PIPE**

EXISTING AND "STRADDLE" MANHOLES  
N.T.S.

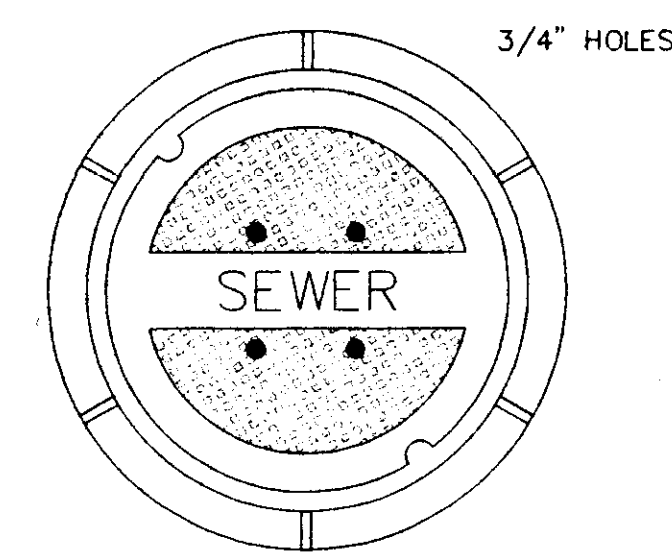

**TOP PLAN OF COVER**

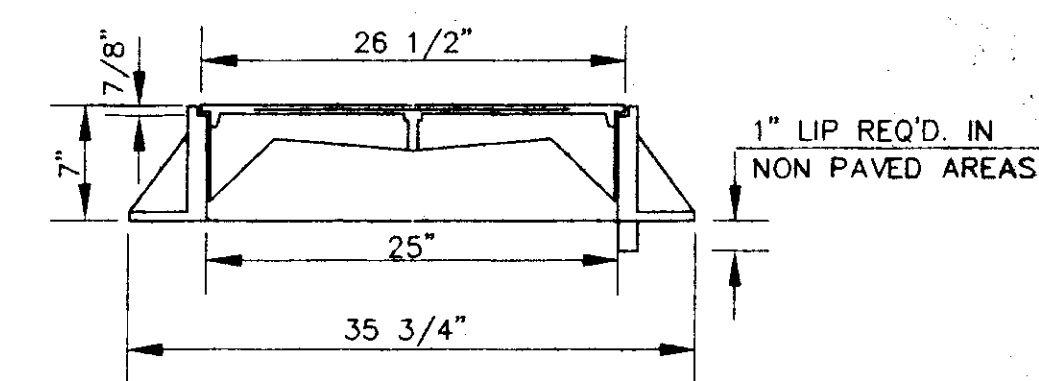

**SECTION**

FRAME & COVER WEIGHT 420 LBS.

**STANDARD MANHOLE FRAME AND COVER**

N.T.S.

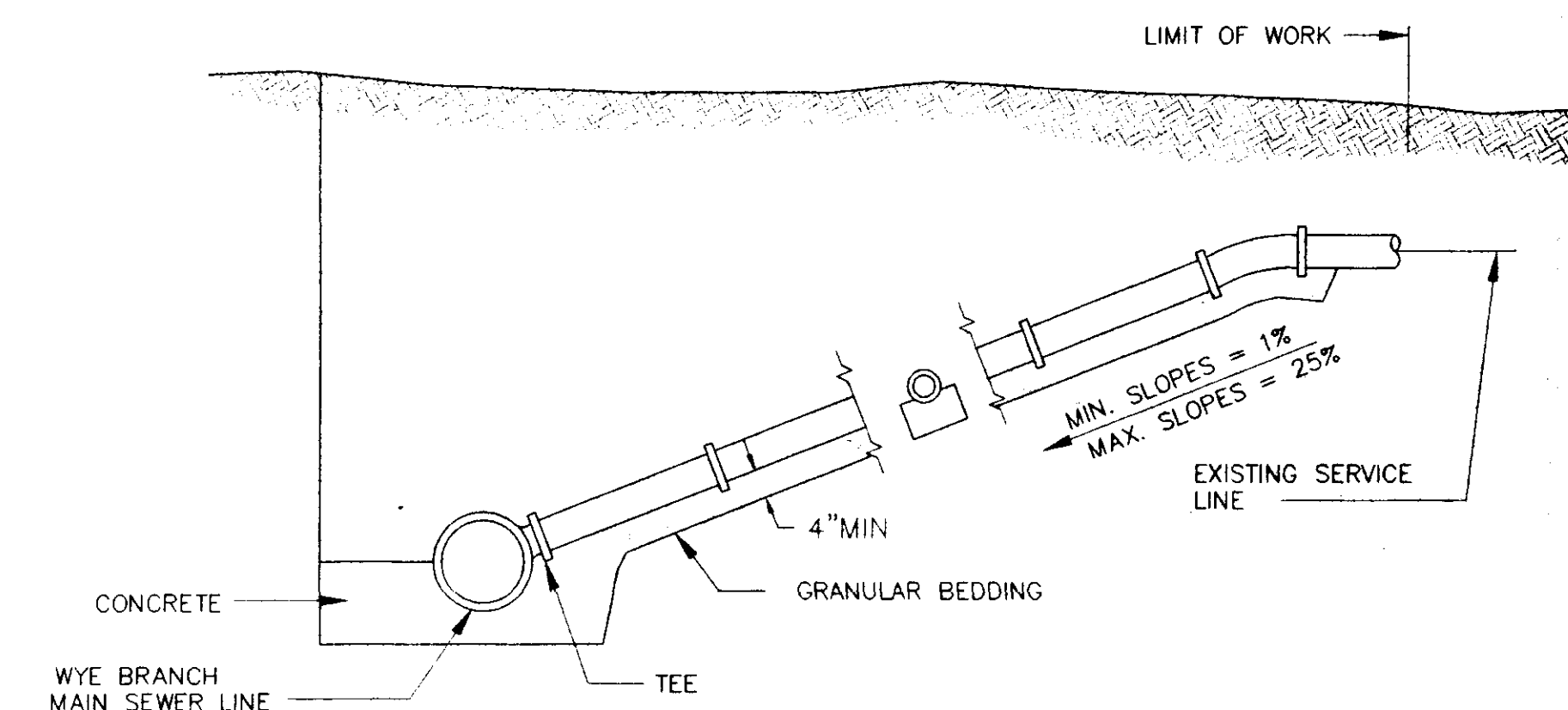

**TYPICAL SERVICE LINE CONNECTION**

NOT TO SCALE

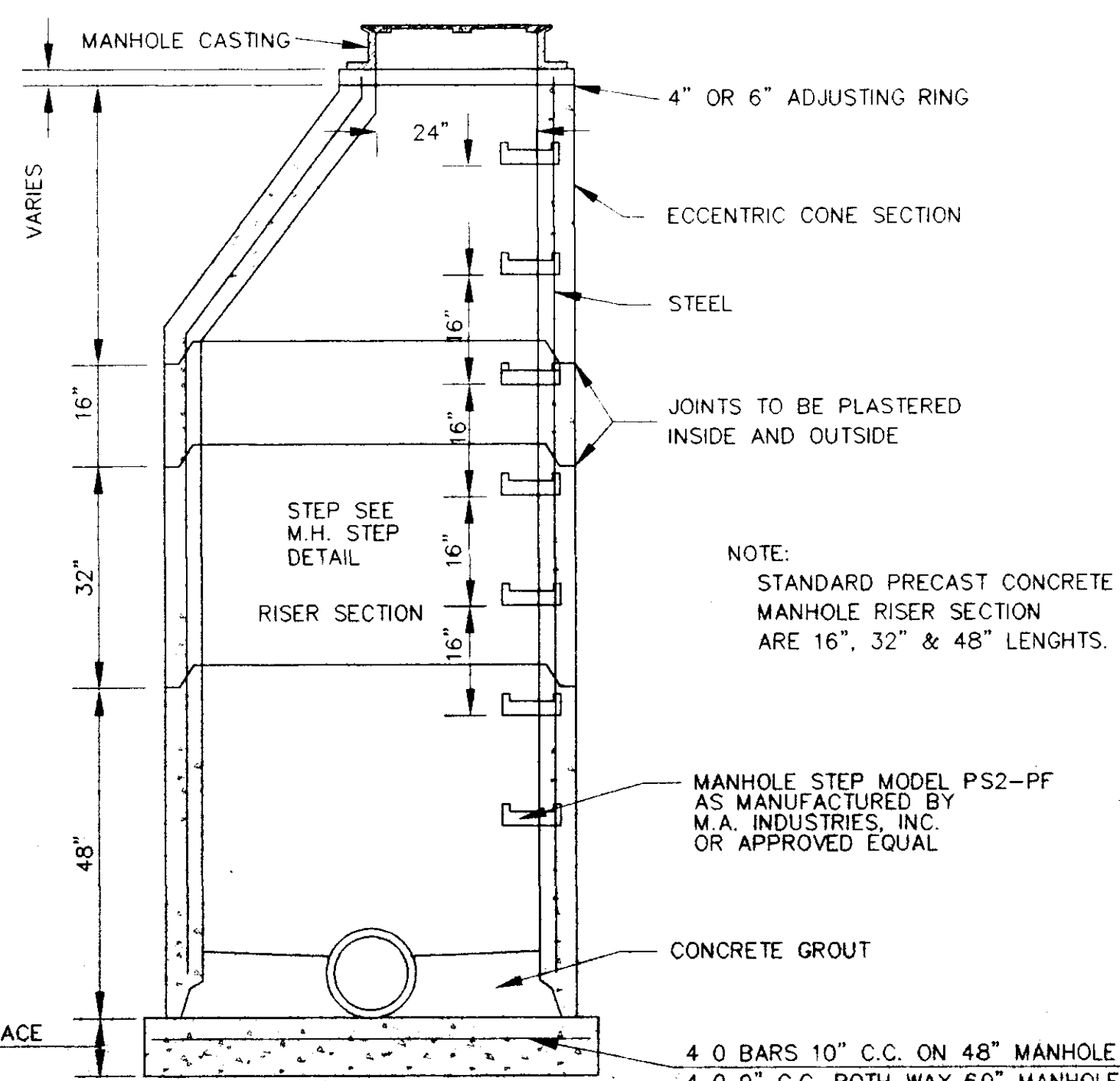

**SECTION OF PRECAST CONCRETE MANHOLE**

N.T.S.

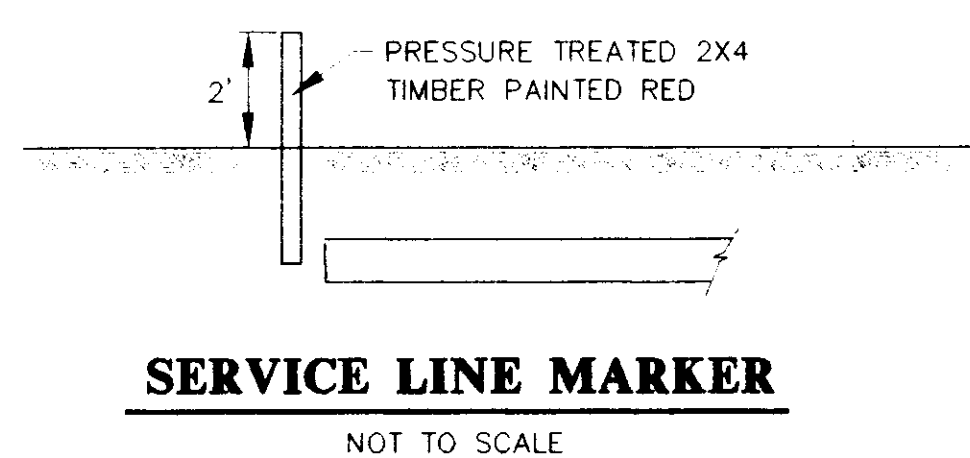

**SERVICE LINE MARKER**

NOT TO SCALE

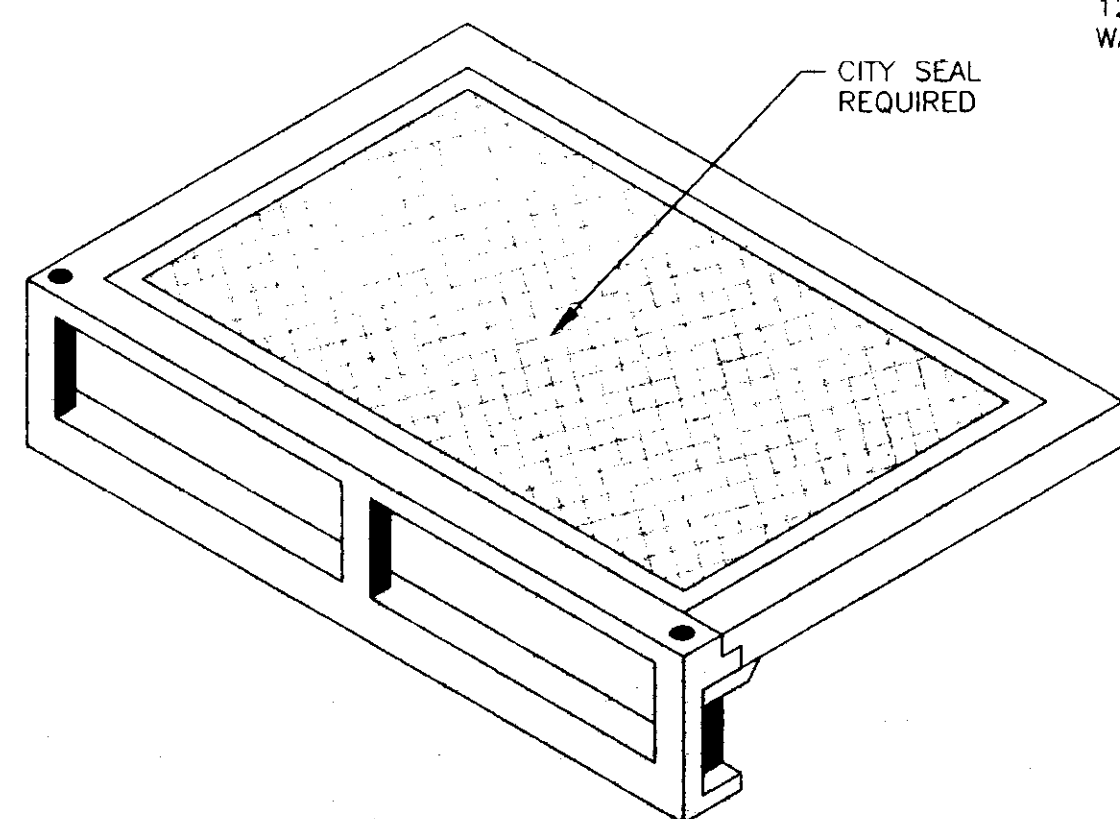

**STANDARD CURB INLET CASTING**

(VULCAN V-4302-1 OR HARPER RCB-7)  
N.T.S.

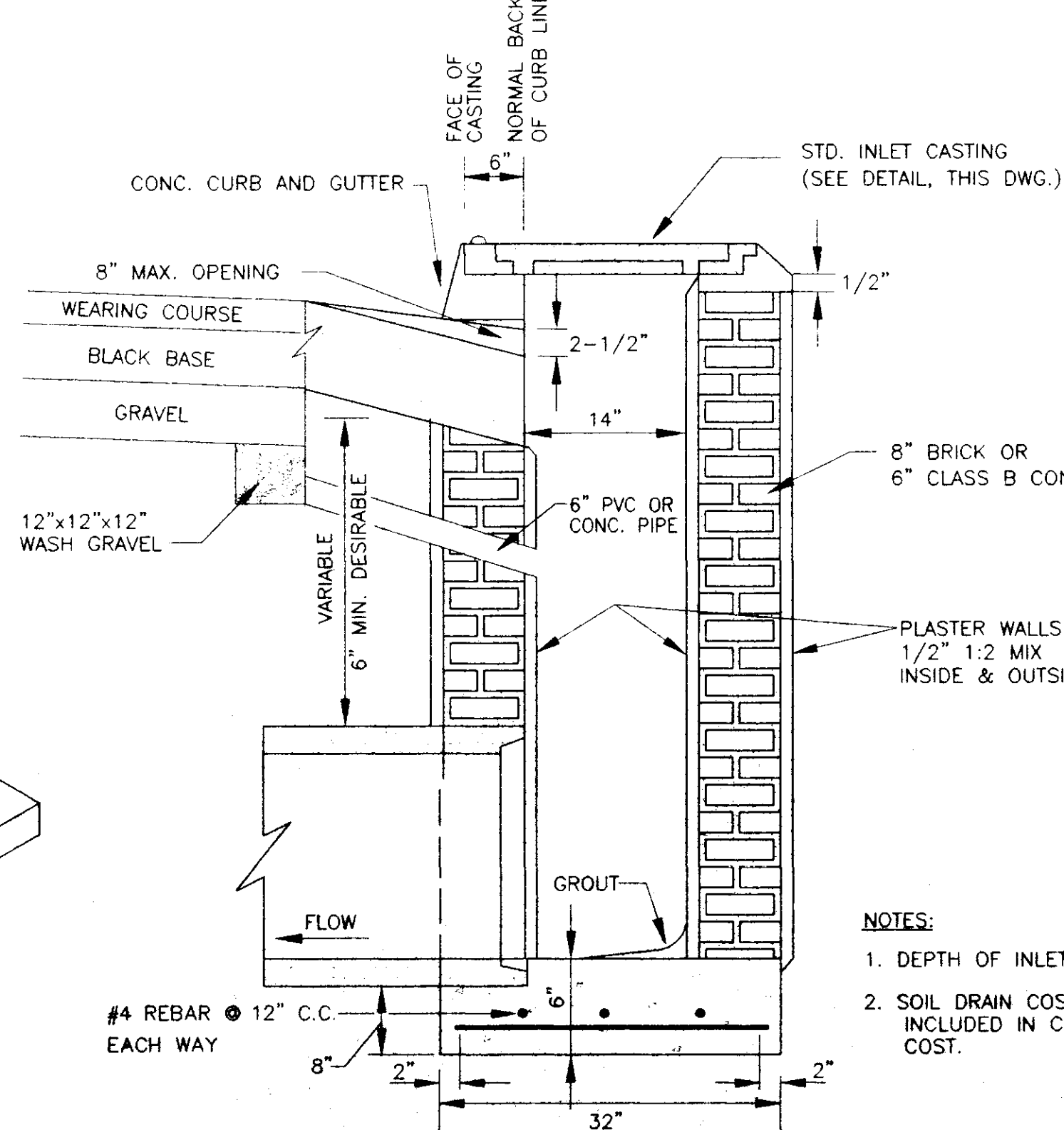

**SECTION OF STANDARD CURB INLET**

NOTES:  
1. DEPTH OF INLET VARIABLE.  
2. SOIL DRAIN COST TO BE INCLUDED IN CONSTRUCTION COST.

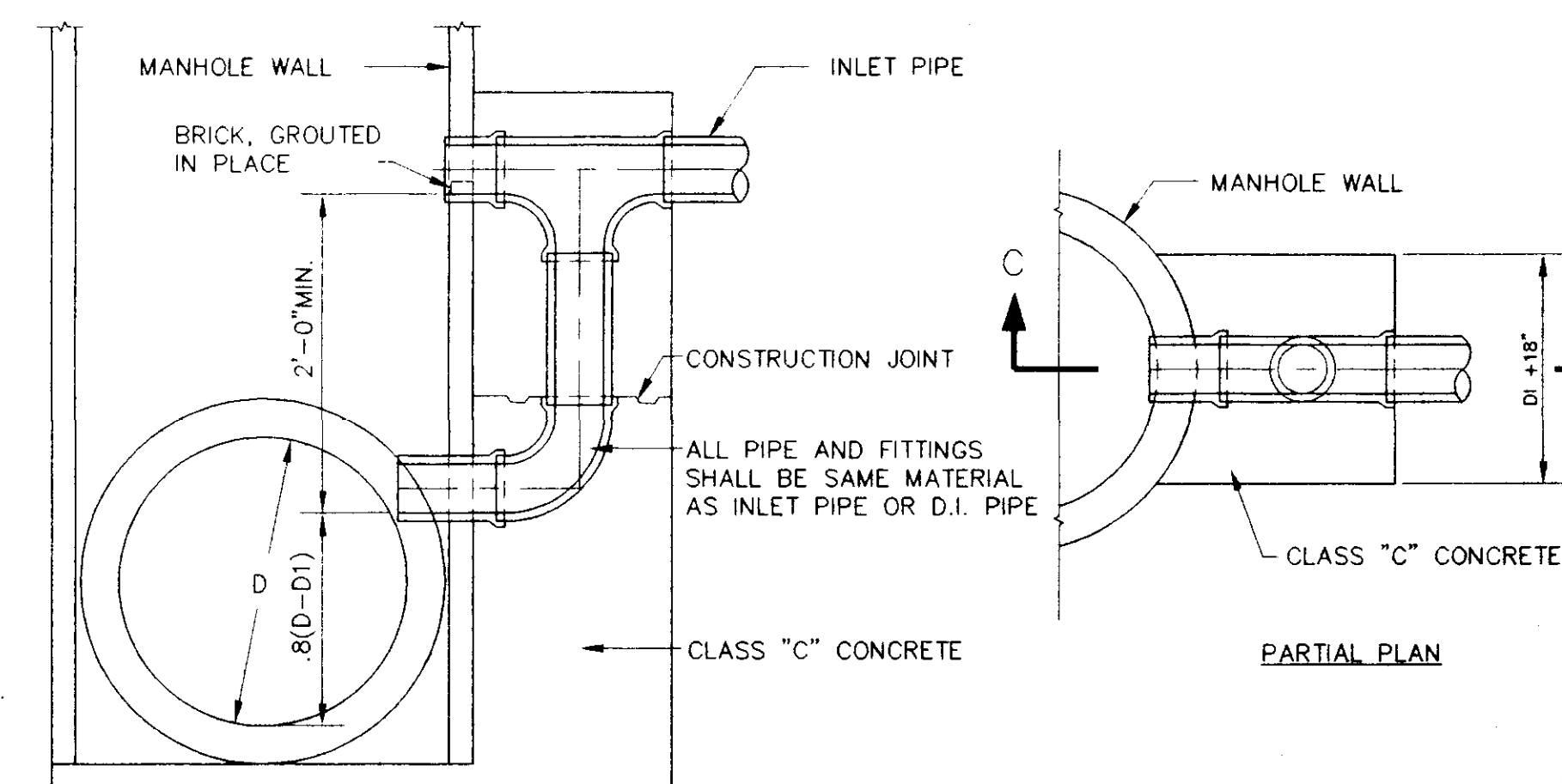

**TYPICAL VERTICAL DROP INLET AT MANHOLE**

N.T.S.

WENDOVER PART 2A  
A DEVELOPMENT OF  
SHADOWOOD PARTNERS, INC.

**STANDARD  
SEWER DETAILS**

**CITY OF RIDGELAND  
MADISON COUNTY, MISSISSIPPI**

DESIGN: RCV	DATE: 03/13		DRAWING NO. <b>10 OF 10</b>
DRAWN: RDP	DATE: 03/13		
CHECK: RCV	DATE: 03/13		
SCALE: AS SHOWN			

